

arteche



INSTRUMENT TRANSFORMERS.
LOW VOLTAGE.

INSULATORS AND WALL BUSHINGS.

This document may be subject to changes.
Contact ARTECHE to confirm the characteristics and
availability of the products described here.



Moving together

CONTENTS

1. Instrument transformers. Low voltage.

Current transformers

- › Metering. Indoor
 - IFG-5 | 6
 - IFP-0 | 6
 - IFW-4 / IFW-5 | 7
 - IFX | 7
- › Metering and protection. Indoor
 - IFE | 8
 - IFG-7 / IFG-8 | 9
 - IFH-6 | 10
 - IFP-1 | 11
 - IFW-0-DS / IFW-4-DS | 11
- › Metering and protection. Indoor / Outdoor
 - IFH-0 | 12
 - IFH-1 | 13
 - IFH-3 | 14
 - IFH-4 | 15
 - IFH-5 | 16
 - IFH-7 | 17
 - IFH-10 | 18
 - IFH-12 | 19
- › Protection. Split-core
 - BAT | 20
 - BAR | 20
 - BAS | 21
- › Homopolar. Indoor / Outdoor
 - BAR | 22
 - IFH-3 | 23
 - ICO-3 | 23
- › Window type for bushings
 - BUSHING CT | 24
- › Auxiliary
 - IRM | 24

Voltage Transformers

- › Metering and protection. Indoor
 - URC | 25

2. Insulators and wall bushings

- › Support insulators. Indoor
 - AR | 27
- › Signal insulators. Indoor
 - ARC | 28
- › Signalling box
 - LAF-1 | 28
- › Wall bushings. Indoor
 - PRU / PRP | 30
 - PBD | 31
 - PBE | 31
 - PPL | 32
- › Wall bushings. Indoor
 - PPE-36 | 33

3. Manufacturing and technology | 34

4. Quality and environment | 36

5. Service | 38

1. INSTRUMENT TRANSFORMERS. LOW VOLTAGE

Current Transformers

Voltage Transformers



CURRENT TRANSFORMERS

>> WINDOW TYPE

Current transformers without primary winding intended to be used in low voltage bars or isolated cables.

RANGE

- › Primary nominal currents up to 10,000 A.
- › Secondary currents 1 and 5 A.
- › Frequencies 50 Hz and 60 Hz.

APPLICATIONS

- › Low voltage panels.
- › Motor control.
- › Primary distribution switchgear.
- › Secondary distribution switchgear.
- › Capacitor banks.
- › Power generation.
- › Dead tank circuit breaker.
- › Railway.

ADVANTAGES

- › Wide range of models with different window sizes available.
- › Multi-ratio transformer for different transformation ratios available.
- › Sealable cover for secondary terminals.
- › Stainless steel screws available.
- › Designs for outdoor service available.
- › Transformer can be assembled in any position.
- › Split core current transformers to install without handling the primary bars or cables.

>> SQUARE WINDOW TYPE

Current transformers for installation in low voltage panel bars where available space is critical.

RANGE

- › Primary nominal currents up to 3,000 A.
- › Secondary currents 1 and 5 A.
- › Frequencies 50 Hz and 60 Hz.

APPLICATIONS

- › Low voltage panels.

ADVANTAGES

- › Variety of models with different window sizes available.
- › Sealable cover for secondary terminals.

>> WITH PRIMARY BAR

Transformers for installation in low voltage measuring panels.

RANGE

- › Primary nominal currents up to 1,000 A.
- › Secondary currents 1 and 5 A.
- › Frequencies 50 Hz and 60 Hz.

APPLICATIONS

- › Low voltage panels.

ADVANTAGES

- › Mechanism for fastening the transformer onto the bar.
- › Sealable cover for secondary terminals.
- › Connection for voltage tap.

IFG-5

CHARACTERISTICS

Primary current A	CL0.2 VA	CL0.5 VA	CL1 VA
50			
75			4
100			7.5
125			10
150			15
200		15	30
250		20	40
300		30	50
400		30	35
500	15	35	40
600	20	50	60

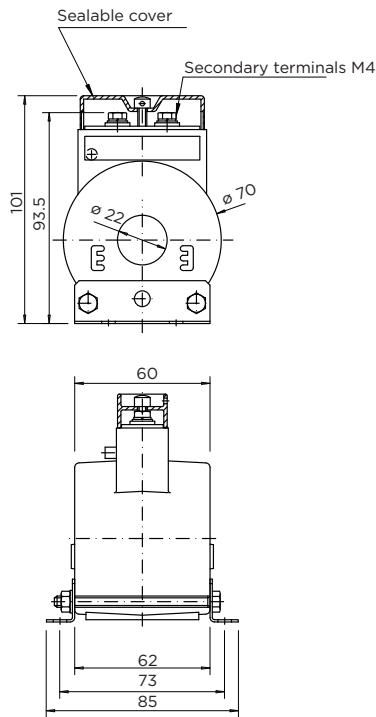

IFP-0

CHARACTERISTICS

Primary current A	Marks A and B	Mark C
5		
10		
20		
30		
40	10 and 15	
50		
75		
100		
150		
200		
300		
400	10 and 15	
500		
600		

Thermal Current: 60xIn

DIMENSIONS

Mark	Current	E
A	Up to 300 A	5
B	From 200 to 600 A	10

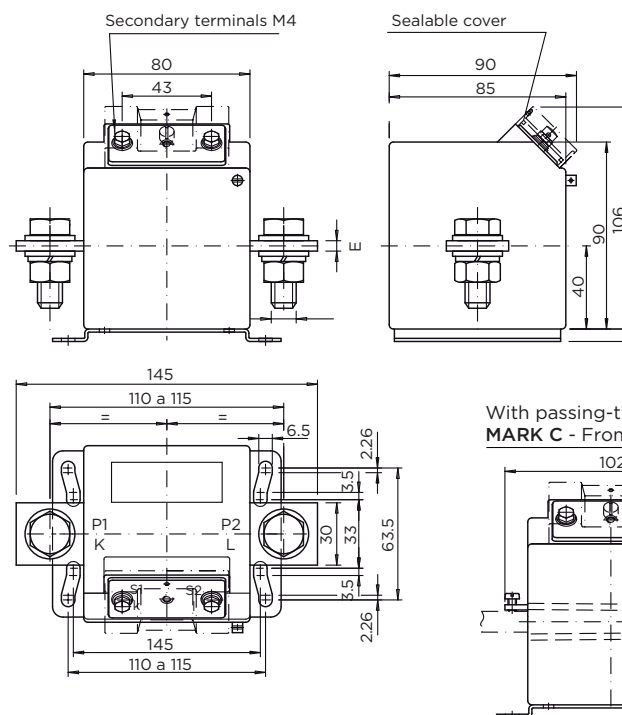

With passing-through hole
MARK C - From 200 to 600 A



IFW-4 • IFW-5

CHARACTERISTICS

Type	Primary current A	CL0.5 VA	CL1 VA
IFW-4	3,000	15	30
	3,500		
	4,000		
IFW-5	3,500		
	4,000		
	5,000		

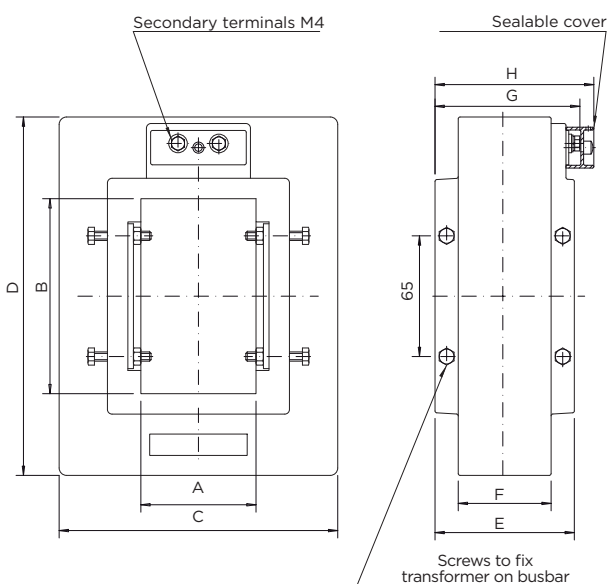

DIMENSIONS

Type	A	B	C	D	E	F	G	H
IFW-4	62	105	150	193	75	50	78	85.5
IFW-5	95	105	190	200	75	50	78	85.5

IFX

CHARACTERISTICS

Type	Primary current A	CL0.5 FS 5 VA
IFX-0	400*	10
	500*	
	600*	
	750*	
	800*	
	1,000*	
IFX-1	1,200*	10 and 15
	1,250*	
	1,500*	
	750*	
	800*	
IFX-2	1,000*	10
	1,200*	
	1,500*	
	2,000*	
	2,000*	
IFX-2	2,500*	10
	3,000*	

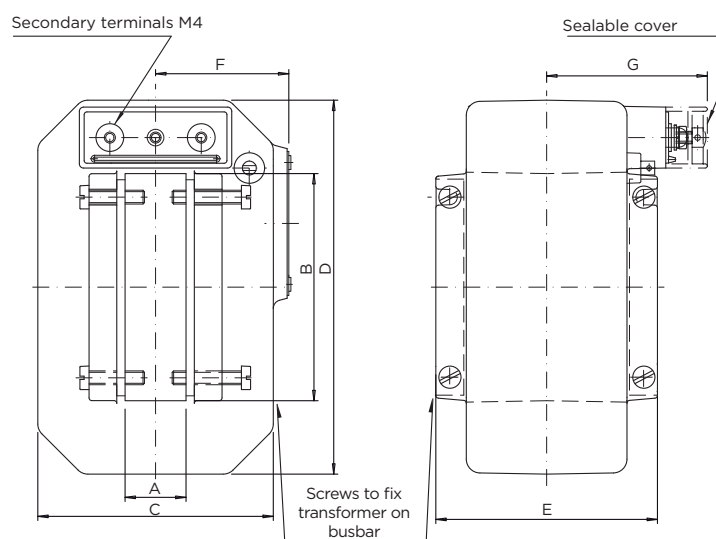

*Extended current rating up: 150%
Thermal Current: 60xIn

DIMENSIONS

Type	A	B	C	D	E	F	G
IFX-0	22	82	85	135	80	48	58
IFX-1	22	102	88	168	74.5	50	55
IFX-2	32	102	102	172	64	56	50

IFE

CHARACTERISTICS

SINGLE PRIMARY RATIO AND ONE SECONDARY

Type	Primary current A	Inner diameter Ø D= 60 mm		Inner diameter Ø D= 80 mm	
		Class and burden METERING	Class and burden PROTECTION	Class and burden METERING	Class and burden PROTECTION
IFE-1	200	5 VA CL1	2.5 VA 5P10		
	250	12.5 VA CL1	2.5 VA 5P10		
	300	5 VA CL0.5	2.5 VA 5P10		
	400	12.5 VA CL0.5	5 VA 5P10		
	500	5 VA CL0.2 25 VA CL0.5	5 VA 5P10 2.5 VA 5P15		
	600	10 VA CL0.2 50 VA CL0.5	5 VA 5P10 2.5 VA 5P20		
	800	20 VA CL0.2 80 VA CL0.5	7.5 VA 5P10 2.5 VA 5P15		
	1000	40 VA CL0.2 100 VA CL0.5	10 VA 5P10 2.5 VA 5P15		
	1200	70 VA CL0.2 120 VA CL0.5	10 VA 5P10 5 VA 5P15		
	IFE-3	150	35 VA CL3	2.5 VA 5P10	25 VA CL3
200		2.5 VA CL0.5 10 VA CL1	5 VA 5P10 5 VA 5P10	5 VA CL1 30 VA CL3	2.5 VA 5P10 2.5 VA 5P15
250		5 VA CL0.5 20 VA CL1	7.5 VA 5P10 2.5 VA 5P20	2.5 VA CL0.5 10 VA CL1	5 VA 5P10 2.5 VA 5P15
300		7.5 VA CL0.5 35 VA CL1	7.5 VA 5P10 2.5 VA 5P20	5 VA CL0.5 20 VA CL1	5 VA 5P10 2.5 VA 5P20
400		5 VA CL0.2 20 VA CL0.5	10 VA 5P10 5 VA 5P20	10 VA CL0.5 45 VA CL1	7.5 VA 5P10 2.5 VA 5P20
500		10 VA CL0.2 40 VA CL0.5	15 VA 5P10 5 VA 5P20	5 VA CL0.2 25 VA CL0.5	10 VA 5P10 2.5 VA 5P20
600		15 VA CL0.2 75 VA CL0.5	15 VA 5P10 7.5 VA 5P20	10 VA CL0.2 40 VA CL0.5	12.5 VA 5P10 5 VA 5P20
800		40 VA CL0.2 175 VA CL0.5	20 VA 5P10 10 VA 5P20	20 VA CL0.2 100 VA CL0.5	15 VA 5P10 5 VA 5P20
1000		75 VA CL0.2 200 VA CL0.5	30 VA 5P10 12.5 VA 5P20	45 VA CL0.2 150 VA CL0.5	20 VA 5P10 7.5 VA 5P20
1200		100 VA CL0.2	30 VA 5P10 12.5 VA 5P20	70 VA CL0.2 175 VA CL0.5	25 VA 5P10 10 VA 5P20
1500				125 VA CL0.2	25 VA 5P10 10 VA 5P20
2000				200 VA CL0.2	35 VA 5P10 10 VA 5P20

DIMENSIONS

Type	Mark	A	B	C	D (±1.5)	E	F	G	H
IFE-1		120	81	83.5	60	40	145	50	164.5
IFE-3	A	120	103	106	60	35	190	55	209
	B				80				

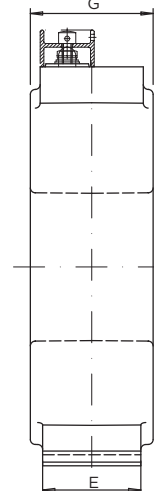
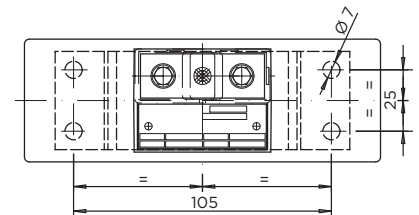
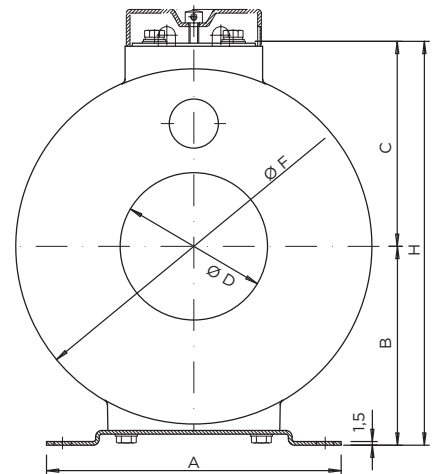

IFG-7 • IFG-8

CHARACTERISTICS

SINGLE PRIMARY RATIO AND ONE SECONDARY

Type	Primary current A	Class and burden METERING	Class and burden PROTECTION
IFG-7	200	2.5 VA CL0.5	2.5 VA 5P10
	250	5 VA CL0.5	2.5 VA 5P10
	300	7.5 VA CL0.5	2.5 VA 5P15
	400	2.5 VA CL0.2	5 VA 5P10
		20 VA CL0.5	2.5 VA 5P15
	500	7.5 VA CL0.2	5 VA 5P10
		40 VA CL0.5	2.5 VA 5P20
	600	15 VA CL0.2	7.5 VA 5P10
		60 VA CL0.5	2.5 VA 5P20
	800	35 VA CL0.2	7.5 VA 5P10
90 VA CL0.5		2.5 VA 5P15	
1000	60 VA CL0.2	12.5 VA 5P10	
	120 VA CL0.5	2.5 VA 5P20	
IFG-8	100	25 VA CL3	2.5 VA 5P10
	150	7.5 VA CL1	2.5 VA 5P15
	200	5 VA CL0.5	2.5 VA 5P10
		5 VA CL0.5	5 VA 5P10
	250	20 VA CL1	2.5 VA 5P15
		2.5 VA CL0.2	10 VA 5P10
	300	15 VA CL0.5	2.5 VA 5P20
		7.5 VA CL0.2	12.5 VA 5P10
	400	40 VA CL0.5	5 VA 5P20
		15 VA CL0.2	15 VA 5P10
500	75 VA CL0.5	5 VA 5P20	
	30 VA CL0.2	15 VA 5P10	
600	125 VA CL0.5	7.5 VA 5P20	
	70 VA CL0.2	20 VA 5P10	
800	180 VA CL0.5	7.5 VA 5P20	
	125 VA CL0.2	30 VA 5P10	
1000	240 VA CL0.5	10 VA 5P20	

DIMENSIONS

Type	A
IFG-7	55
IFG-8	85



IFG-7

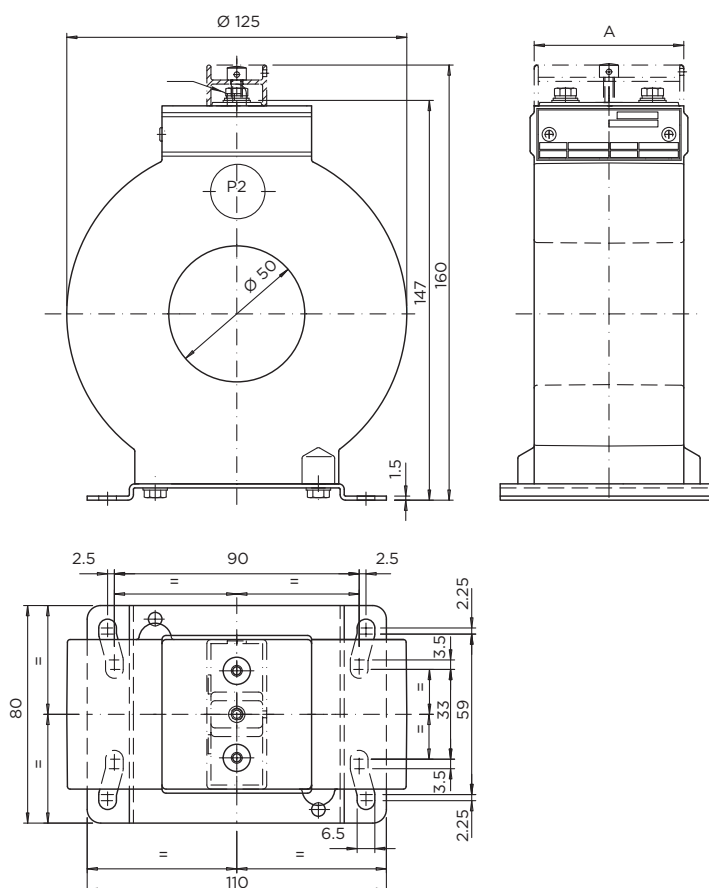

IFH-6

DIMENSIONS & CHARACTERISTICS

D	L	Mark	Primary current A	METERING	PROTECTION	METERING + PROTECTION
130	I		100	5 VA CL1	5 VA 5P20	
			200	10 VA CL0.5	12.5 VA 5P20	5 VA CL1 + 7.5 VA 5P20
			400	15 VA CL0.2	25 VA 5P20	10 VA CL0.5 + 15 VA 5P20
			600	15 VA CL0.2S	40 VA 5P20	15 VA CL0.2 + 15 VA 5P20
			1,000	70 VA CL0.2S	70 VA 5P20	15 VA CL0.2S + 30 VA 5P20
60	180	B	100		7.5 VA 5P20	5 VA CL3 + 5 VA 5P20
			200		20 VA 5P20	5 VA CL1 + 15 VA 5P20
			400		40 VA 5P20	15 VA CL0.5 + 25 VA 5P20
			600		60 VA 5P20	15 VA CL0.2S + 35 VA 5P20
			1,000		100 VA 5P20	15 VA CL0.2S + 60 VA 5P20
225	E	100		10 VA 5P20	5 VA CL3 + 7.5 VA 5P20	
		200		25 VA 5P20	10 VA CL1 + 20 VA 5P20	
		400		55 VA 5P20	20 VA CL0.5 + 40 VA 5P20	
		600		85 VA 5P20	15 VA CL0.2 + 60 VA 5P20	
		1,000		140 VA 5P20	15 VA CL0.2S + 90 VA 5P20	
130	J	100	15 VA CL3	5 VA 5P20		
		200	5 VA CL0.5	12.5 VA 5P20	2.5 VA CL0.5 + 5 VA 5P20	
		400	10 VA CL0.2	25 VA 5P20	12.5 VA CL0.5 + 12.5 VA 5P20	
		600	35 VA CL0.2	40 VA 5P20	15 VA CL0.2 + 15 VA 5P20	
		1,000	40 VA CL0.2S	70 VA 5P20	15 VA CL0.2S + 20 VA 5P20	
80	180	C	2,000	300 VA CL0.2S	135 VA 5P20	15 VA CL0.2S + 65 VA 5P20
			100		7.5 VA 5P20	
			200		20 VA 5P20	2.5 VA CL0.5 + 12.5 VA 5P20
			400		40 VA 5P20	12.5 VA CL0.5 + 25 VA 5P20
			600		65 VA 5P20	15 VA CL0.2 + 35 VA 5P20
225	F	1,000		100 VA 5P20	15 VA CL0.2S + 60 VA 5P20	
		2,000		200 VA 5P20		
		100		10 VA 5P20		
		200		25 VA 5P20	10 VA CL1 + 20 VA 5P20	
		400		55 VA 5P20	20 VA CL0.5 + 40 VA 5P20	
110	130	L	600		85 VA 5P20	12.5 VA CL0.2 + 60 VA 5P20
			1,000		140 VA 5P20	15 VA CL0.2S + 90 VA 5P20
			100	15 VA CL3	5 VA 5P20	
			200	5 VA CL0.5	12.5 VA 5P20	2.5 VA CL0.5 + 5 VA 5P20
			400	7.5 VA CL0.2	25 VA 5P20	12.5 VA CL0.5 + 12.5 VA 5P20
130	A	600	35 VA CL0.2	40 VA 5P20	15 VA CL0.2 + 15 VA 5P20	
		1,000	40 VA CL0.2S	70 VA 5P20	15 VA CL0.2S + 20 VA 5P20	
		200	15 VA CL1	10 VA 5P20	5 VA CL1 + 5 VA 5P20	
		400	30 VA CL0.5	20 VA 5P20	5 VA CL0.5 + 10 VA 5P20	
		600	20 VA CL0.2	30 VA 5P20	7.5 VA CL0.2 + 15 VA 5P20	
130	180	D	1,000	25 VA CL0.2S	50 VA 5P20	20 VA CL0.2 + 25 VA 5P20
			1,500	85 VA CL0.2S	75 VA 5P20	20 VA CL0.2 S + 25 VA 5P20
			2,000	200 VA CL0.2S	100 VA 5P20	25 VA CL0.2S + 50 VA 5P20
			200		15 VA 5P20	7.5 VA CL1 + 7.5 VA 5P20
			400		30 VA 5P20	15 VA CL0.5 + 15 VA 5P20
225	G	600		45 VA 5P20	10 VA CL0.2 + 25 VA 5P20	
		1,000		80 VA 5P20	10 VA CL0.2 S + 45 VA 5P20	
		200		20 VA 5P20	7.5 VA CL1 + 12.5 VA 5P20	
		400		45 VA 5P20	15 VA CL0.5 + 25 VA 5P20	
		600		65 VA 5P20	7.5 VA CL0.2 + 45 VA 5P20	
160	225	K	1,000		115 VA 5P20	7.5 VA CL0.2 S + 70 VA 5P20
			200	7.5 VA CL1	10 VA 5P20	
			400	15 VA CL0.5	20 VA 5P20	7.5 VA CL0.5 + 10 VA 5P20
			600	12.5 VA CL0.2	25 VA 5P20	20 VA CL0.5 + 15 VA 5P20
			1,000	10 VA CL0.2S	50 VA 5P20	25 VA CL0.2 + 25 VA 5P20
205	180	H	1,500	50 VA CL0.2S	55 VA 5P20	15 VA CL0.2 S + 40 VA 5P20
			1,000	15 VA CL0.5	15 VA 5P10	10 VA CL0.5 + 10 VA 5P10
			1,200	20 VA CL0.5	20 VA 5P10	15 VA CL0.5 + 15 VA 5P10
			1,600	25 VA CL0.5	25 VA 5P10	10 VA CL0.5 + 10 VA 5P10
			100		10 VA 5P20	5 VA CL3 + 7.5 VA 5P20
70	225	M	200		25 VA 5P20	10 VA CL1 + 20 VA 5P20
			400		55 VA 5P20	20 VA CL0.5 + 40 VA 5P20
			600		85 VA 5P20	15 VA CL0.2 + 60 VA 5P20
			1,000		140 VA 5P20	15 VA CL0.2S + 90 VA 5P20

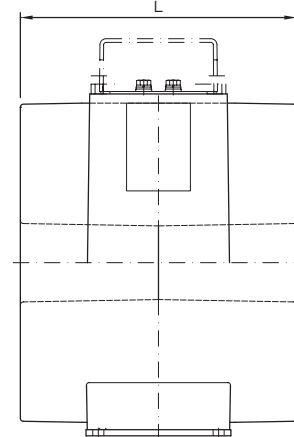
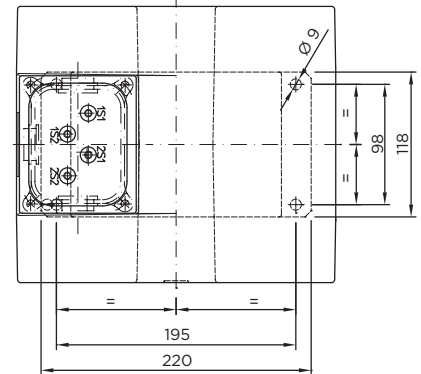
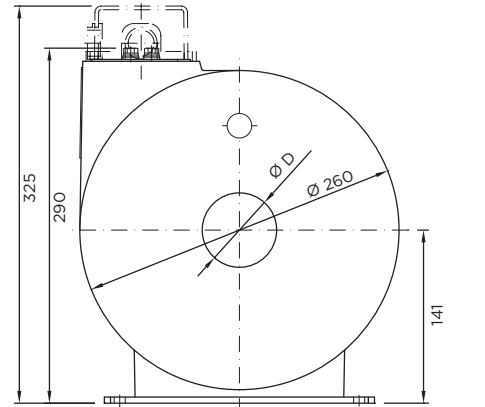

IFP-1

MARK A - Up to 1,000 A

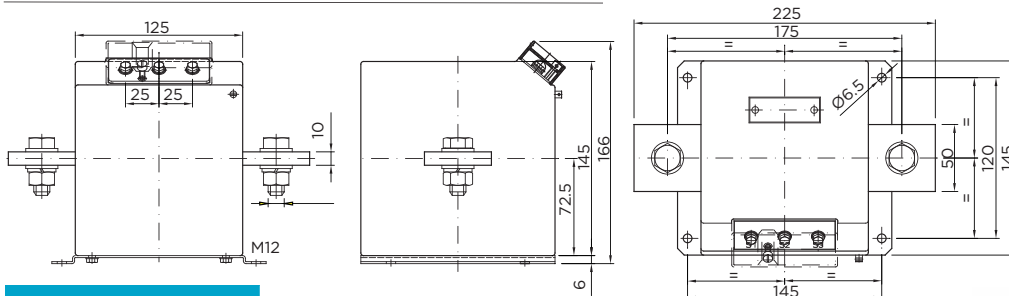

CHARACTERISTICS

Mark	Primary current A	CL0,2 VA	SP10 VA
A	5 to 250	30	20
	300	15	15
	400		20
	600		30
	800	30	35
	900		40
B	1,000		45
	300	15	15
	400		20
	500		25
	600		30
	800	30	35
	900		40
	1,000		45

With passing - Through hole
MARK B - From 250 to 1000 A

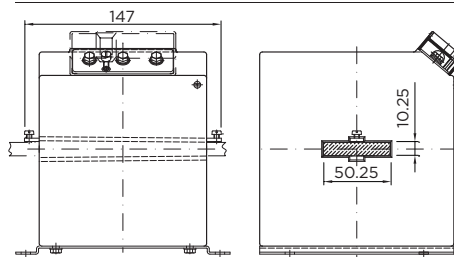

Thermal Current: 60xIn

IFW-O/DS • IFW-4/DS

CHARACTERISTICS

Type	Ratio (A)	Burden VA PROTECTION	Ratio (A)	Class and burden METERING + PROTECTION
IFW-O/DS	250/5	7.5 VA 10P5		
	300/5	10 VA 10P5		
	350/5	12.5 VA 10P5		
	400/5	15 VA 10P5 or 5 VA 5P10		
	500/5	15 VA 10P5 or 7.5 VA 5P10	500/5-5	10 VA CL1 + 5 VA 5P10 5 VA 10P10
	600/5	20 VA 10P5 or 10 VA 5P10	600/5-5	10 VA CL1 + 7.5 VA 5P10 7.5 VA 10P10
	1,000/5	30 VA 10P5 or 15 VA 5P10	1,000/5-5	15 VA CL0.5 + 10 VA 5P10 10 VA 10P10
	1,250/5	30 VA 10P5 or 15 VA 5P10	1,250/5-5	15 VA CL0.5 + 10 VA 5P10 12.5 VA 10P10
	1,500/5	40 VA 10P5 or 20 VA 5P10	1,500/5-5	15 VA CL0.5 + 15 VA 5P10 15 VA 10P10
	2,000/5	45 VA 10P5 20 VA 5P10	2,000/5-5	15 VA CL0.5 + 15 VA 5P10 20 VA 10P10
IFW-4/DS	2,500/5	40 VA 10P5 30 VA 5P10	2,500/5-5	15 VA CL0.5 + 20 VA 5P10 25 VA 10P10
	3,000/5	40 VA 10P5 30 VA 5P10	3,000/5-5	15 VA CL0.5 + 25 VA 5P10 30 VA 10P10
	3,500/5	40 VA 10P5 30 VA 5P10	3,500/5-5	15 VA CL0.5 + 25 VA 5P10 30 VA 10P10
	4,000/5	45 VA 10P5 40 VA 5P10	4,000/5-5	15 VA CL0.5 + 30 VA 5P10 35 VA 10P10



DIMENSIONS

Type	A	B	C	D	E	F	G
IFW-O/DS	20	62	84	126	126	80	105
IFW-4/DS	62	105	150	193	136	90	115

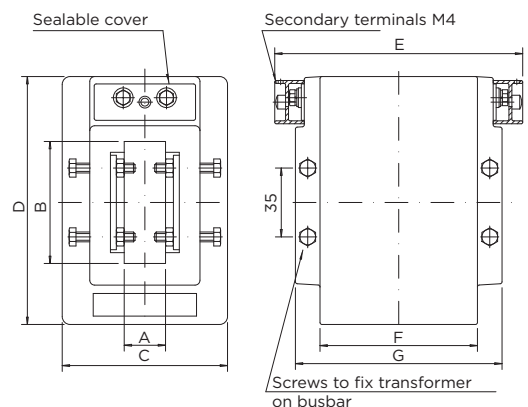

IFH-0

Secondary terminals M6 (max. 6)

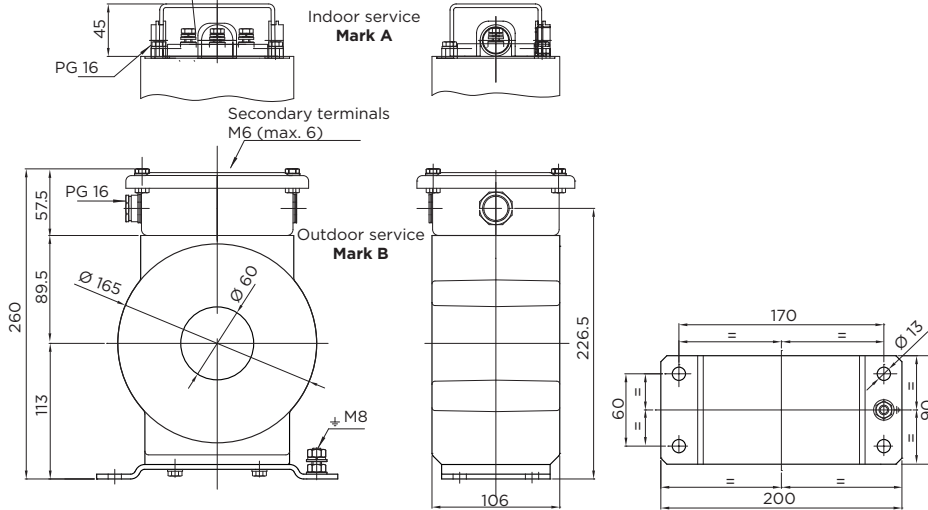

CHARACTERISTICS

Primary current A	ONE SECONDARY		TWO SECONDARIES
	METERING	PROTECTION	METERING + PROTECTION
100		5 VA 5P10	
150	10 VA CL1	10 VA 5P10	
200	25 VA CL1	10 VA 5P10	5 VA CL1 + 10 VA 5P5
250	25 VA CL1	15 VA 5P10	15 VA CL1 + 5 VA 5P10
300	20 VA CL0.5	15 VA 5P10	20 VA CL1 + 5 VA 5P10
400	40 VA CL0.5	20 VA 5P10	15 VA CL0.5 + 10 VA 5P10
500	50 VA CL0.5	30 VA 5P10	15 VA CL0.5 + 15 VA 5P10
600	50 VA CL0.5	15 VA 5P20	20 VA CL0.5 + 20 VA 5P10
750	65 VA CL0.5	20 VA 5P20	30 VA CL0.5 + 25 VA 5P10
800			40 VA CL0.5 + 30 VA 5P10
1,000	30 VA CL0.2	25 VA 5P20	50 VA CL0.5 + 35 VA 5P10
1,200	30 VA CL0.2	30 VA 5P20	50 VA CL0.5 + 45 VA 5P10



IFH-1

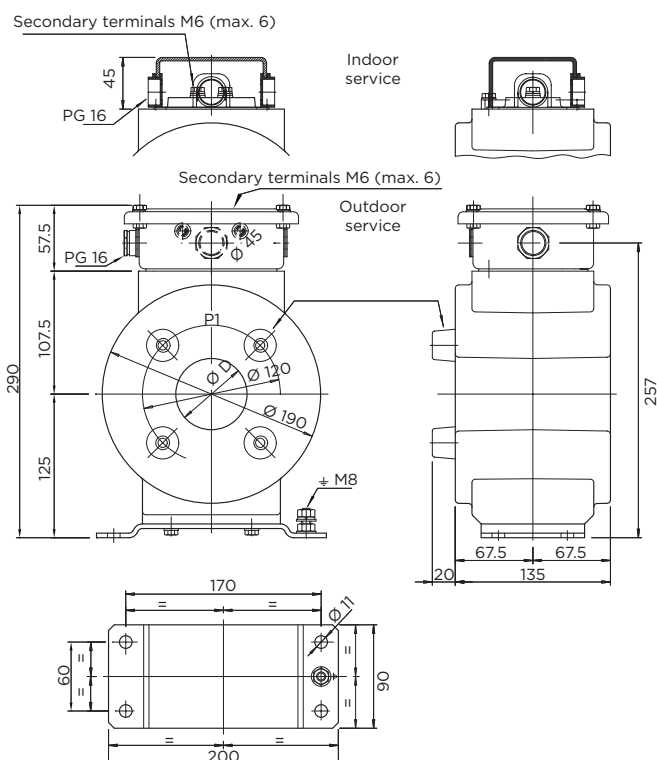

CHARACTERISTICS

Primary current A	INNER DIAMETER (ØD= 60 mm)			INNER DIAMETER (ØD= 80 mm)		
	ONE SECONDARY		TWO SECONDARIES	ONE SECONDARY		TWO SECONDARIES
	METERING	PROTECTION	METERING + PROTECTION	METERING	PROTECTION	METERING + PROTECTION
75	15 VA CL3	7.5 VA 10P10		10 VA CL3	10 VA 10P5	
100	50 VA CL3	12.5 VA 5P10		40 VA CL3	7.5 VA 10P10	
150	20 VA CL1	15 VA 5P10	30 VA CL3 + 10 VA 5P10	10 VA CL1	12.5 VA 5P10	20 VA CL3 + 5 VA 5P10
200	10 VA CL0.5	20 VA 5P10	10 VA CL1 + 12.5 VA 5P10	25 VA CL1	7.5 VA 5P20	5 VA CL1 + 7.5 VA 5P10
250	20 VA CL0.5	25 VA 5P10	20 VA CL1 + 15 VA 5P10	12.5 VA CL0.5	10 VA 5P20	10 VA CL1 + 10 VA 5P10
300	40 VA CL0.5	15 VA 5P20	10 VA CL0.5 + 20 VA 5P10	20 VA CL0.5	12.5 VA 5P20	15 VA CL1 + 12.5 VA 5P10
400	90 VA CL0.5	25 VA 5P20	10 VA CL0.5 + 15 VA 5P20	50 VA CL0.5	15 VA 5P20	10 VA CL0.5 + 15 VA 5P10
500	50 VA CL0.2	30 VA 5P20	20 VA CL0.5 + 25 VA 5P20	25 VA CL0.2	20 VA 5P20	12.5 VA CL0.5 + 5 VA 5P20
600	75 VA CL0.2	35 VA 5P20	30 VA CL0.5 + 25 VA 5P20	40 VA CL0.2	20 VA 5P20	20 VA CL0.5 + 15 VA 5P20
800	100 VA CL0.2	50 VA 5P20	15 VA CL0.2 + 35 VA 5P20	100 VA CL0.2	30 VA 5P20	40 VA CL0.5 + 20 VA 5P20
1,000	100 VA CL0.2	60 VA 5P20	30 VA CL0.2 + 45 VA 5P20	100 VA CL0.2	35 VA 5P20	20 VA CL0.2 + 25 VA 5P20
1,200	100 VA CL0.2	60 VA 5P20	50 VA CL0.2 + 50 VA 5P20	100 VA CL0.2	45 VA 5P20	30 VA CL0.2 + 30 VA 5P20
1,500				100 VA CL0.2	50 VA 5P20	50 VA CL0.2 + 40 VA 5P20
2,000				100 VA CL0.2	75 VA 5P20	100 VA CL0.2 + 40 VA 5P20

DIMENSIONS

Mark	Ø D (±1.5)	Service
A	60	Outdoor
B	80	
C	60	Indoor
D	80	

IFH-3

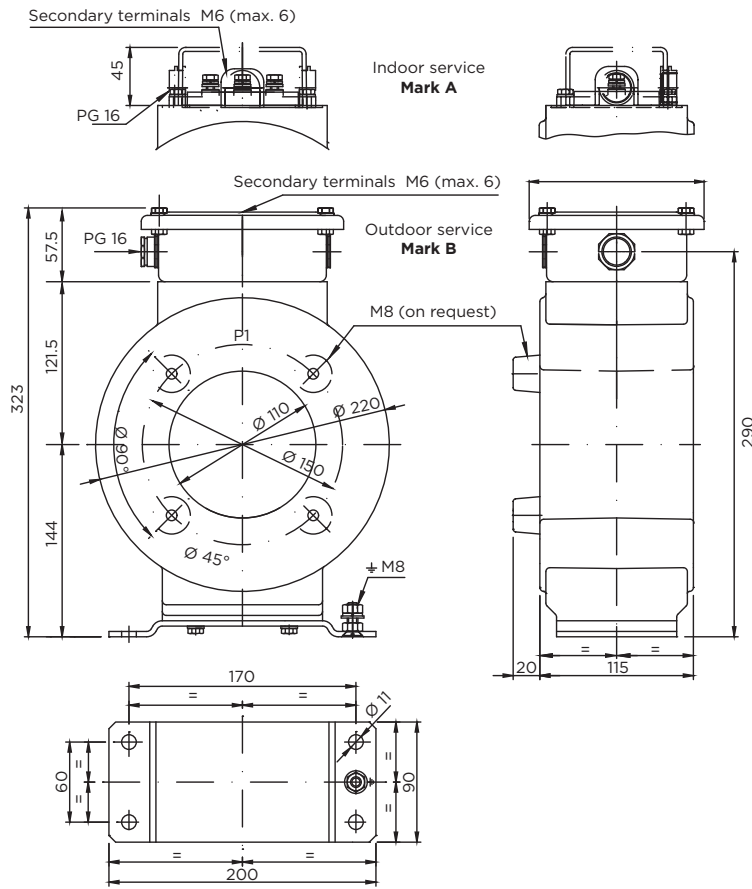

CHARACTERISTICS

Primary current A	ONE SECONDARY		TWO SECONDARIES
	METERING	PROTECTION	METERING + PROTECTION
150	5 VA CL1	5 VA 5P20	
200	15 VA CL1	5 VA 5P20	
250	5 VA CL0.5	10 VA 5P20	
300	12.5 VA CL0.5	10 VA 5P20	5 VA CL1 + 5 VA 5P20
350	20 VA CL0.5	12.5 VA 5P20	5 VA CL0.5 + 5 VA 5P20
400	20 VA CL0.5	15 VA 5P20	5 VA CL0.5 + 7.5 VA 5P20
500	25 VA CL0.5	20 VA 5P20	10 VA CL0.5 + 10 VA 5P20
600	50 VA CL0.5	20 VA 5P20	12.5 VA CL0.5 + 12.5 VA 5P20
1,000	50 VA CL0.5	20 VA 5P20	
1,500	50 VA CL0.5	20 VA 5P20	30 VA CL0.5 + 30 VA 5P20
2,000	50 VA CL0.5	20 VA 5P20	
3,000	50 VA CL0.5	20 VA 5P20	30 VA CL0.5 + 30 VA 5P20

IFH-4

Secondary terminals M5 (max. 9)
Secondary terminals M6

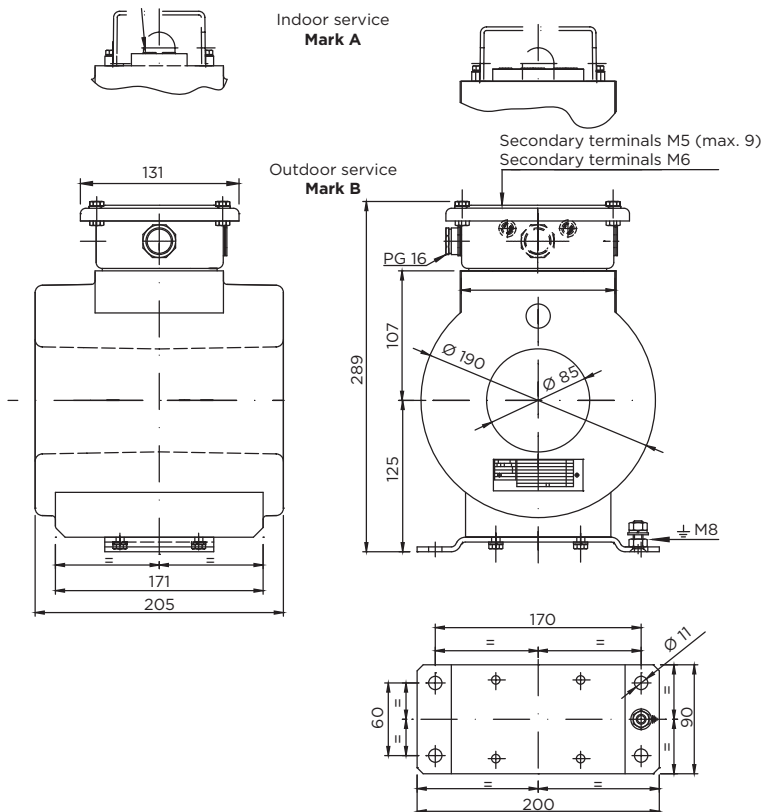

CHARACTERISTICS

Primary current A	ONE SECONDARY		TWO SECONDARIES
	METERING	PROTECTION	METERING + PROTECTION
100	5 VA CL1	5 VA 5P20	
150	15 VA CL1	10 VA 5P20	5 VA CL1 + 5 VA 5P20
200	7.5 VA CL0.5	12.5 VA 5P20	15 VA CL1 + 7.5 VA 5P20
300	30 VA CL0.5	20 VA 5P20	15 VA CL0.5 + 10 VA 5P20
400	15 VA CL0.2	25 VA 5P20	7.5 VA CL0.2 + 10 VA 5P20
500	30 VA CL0.2	30 VA 5P20	15 VA CL0.2 + 15 VA 5P20
700	20 VA CL0.2	45 VA 5P20	10 VA CL0.2S + 20 VA 5P20
1,000	60 VA CL0.2	65 VA 5P20	25 VA CL0.2S + 25 VA 5P20
2,000	400 VA CL0.2	100 VA 5P20	100 VA CL0.2S + 50 VA 5P20

IFH-5

Secondary terminals M6 (max. 6)

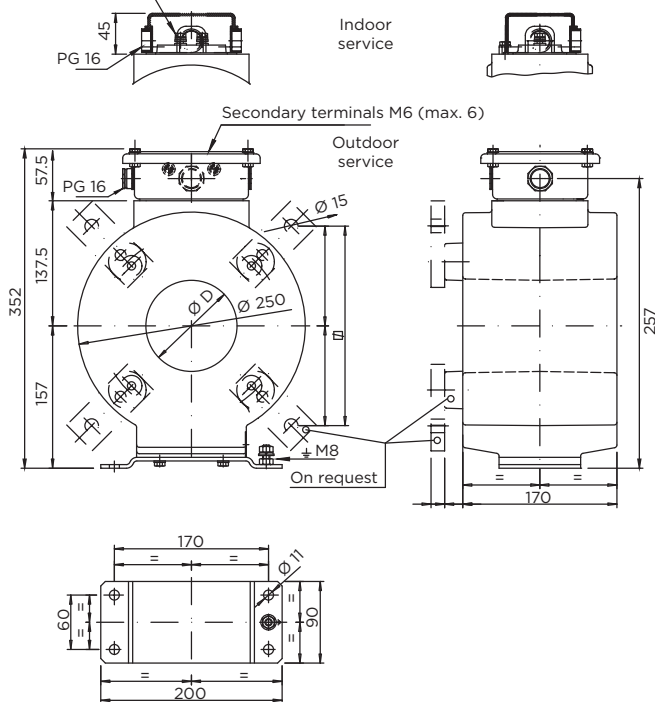

➤ IFH-5. Side mounting on request installation horizontal or vertical.

CHARACTERISTICS

Primary current A	ONE SECONDARY			TWO SECONDARIES	
	Inner diameter (ØD= 100 mm)	Inner diameter (ØD= 130 mm)	Inner diameter (ØD= 145 mm)	Inner diameter (ØD= 100 mm)	Inner diameter (ØD= 130 mm)
	PROTECTION			METERING + PROTECTION	
200	20 VA 5P20	12.5 VA 5P20	5 VA 5P20	10 VA CL3 + 1 ÷ 10 VA 5P20	7.5 VA CL1 + 7.5 VA 5P20
250	25 VA 5P20	15 VA 5P20	7.5 VA 5P20	15 VA CL1 + 15 VA 5P20	15 VA CL1 + 10 VA 5P20
300	30 VA 10P20	20 VA 5P20	10 VA 5P20	10 VA CL0.5 + 15 VA 5P20	5 VA CL0.5 + 10 VA 5P20
500	45 VA 10P20	30 VA 5P20	15 VA 5P20	25 VA CL0.5 + 25 VA 5P20	20 VA CL0.5 + 20 VA 5P20
750	50 VA 10P20	50 VA 5P20	25 VA 5P20	30 VA CL0.5 + 30 VA 5P20	25 VA CL0.5 + 30 VA 5P20
1,000	50 VA 10P20	50 VA 5P20	30 VA 5P20	30 VA CL0.5 + 40 VA 5P20	30 VA CL0.5 + 40 VA 5P20
2,000	50 VA 10P20	50 VA 5P20	50 VA 5P20	30 VA CL0.5 + 40 VA 5P20	30 VA CL0.5 + 40 VA 5P20
3,000	50 VA 10P20	50 VA 5P20	50 VA 5P20	30 VA CL0.5 + 40 VA 5P20	30 VA CL0.5 + 40 VA 5P20
6,000			45 VA 5P20		

DIMENSIONS

Mark	D (±1.5)	Service
A	100	Outdoor
B	130	
C	100	
D	130	Indoor
E	145	Outdoor
F	145	Indoor

IFH-7

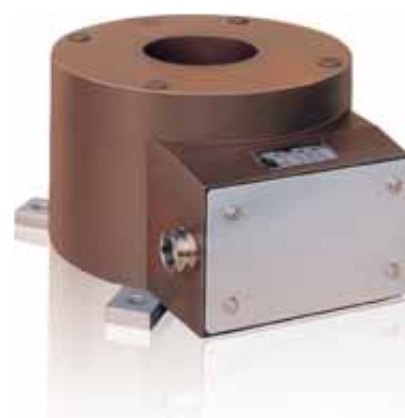
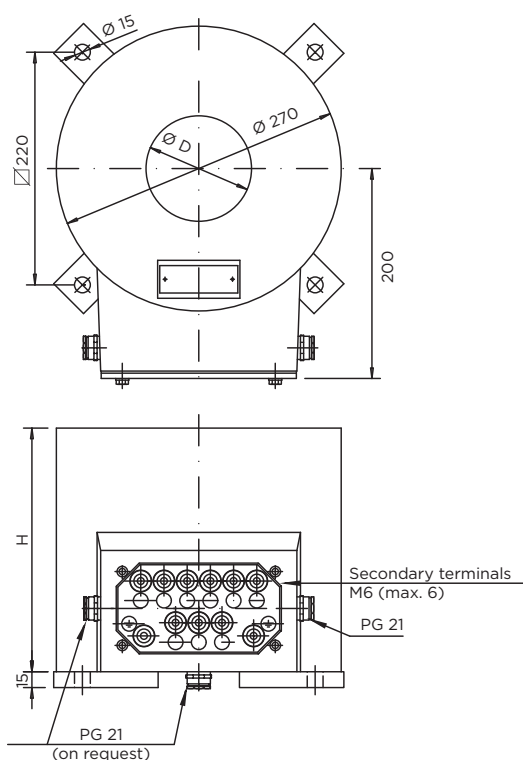

CHARACTERISTICS			
Mark	Primary current A	PROTECTION	PROTECTION
1	100	15 VA 5P10	7.5 VA 5P20
	200	30 VA 5P10	15 VA 5P20
	300	50 VA 5P10	20 VA 5P20
	400	60 VA 5P10	30 VA 5P20
	500	75 VA 5P10	40 VA 5P20
	50	7.5 VA 5P10	2.5 VA 5P20
2	75	15 VA 5P10	5 VA 5P20
	100	25 VA 5P10	10 VA 5P20
	150	40 VA 5P10	15 VA 5P20
	250	60 VA 5P10	30 VA 5P20
	300	70 VA 5P10	35 VA 5P20
	600	100 VA 5P10	60 VA 5P20
3	1,000	100 VA 5P10	100 VA 5P20
	50	10 VA 5P10	5 VA 5P20
	100	30 VA 5P10	15 VA 5P20
	200	60 VA 5P10	30 VA 5P20
4	300	100 VA 5P10	50 VA 5P20
	50	15 VA 5P10	7.5 VA 5P20
	100	40 VA 5P10	20 VA 5P20
	150	60 VA 5P10	30 VA 5P20

DIMENSIONS			
Mark	H	D	Weight (kg)
1	166	100	40
2	231		55
3	296		75
4	361		90

IFH-10

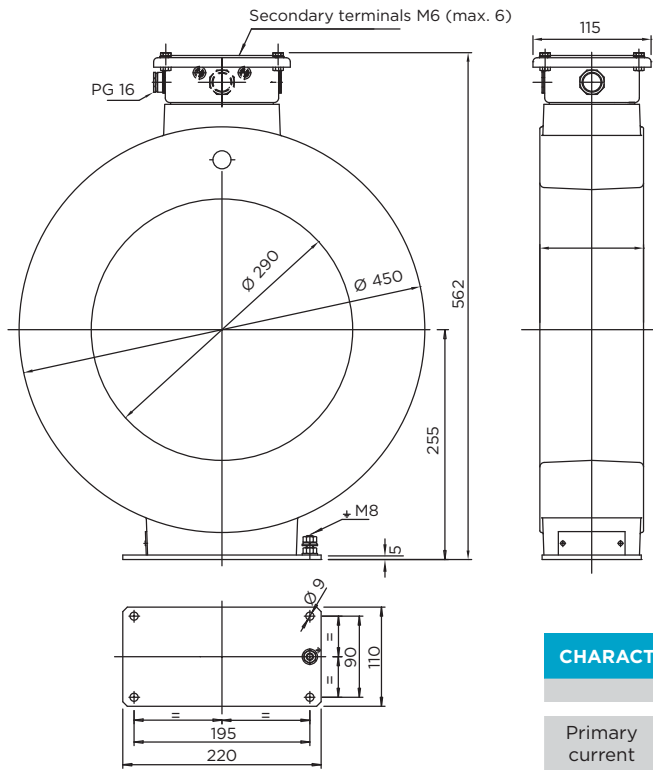

CHARACTERISTICS			
	ONE SECONDARY		TWO SECONDARIES
Primary current A	METERING	PROTECTION	METERING + PROTECTION
4,000			
5,000			
6,000	30 VA CL0.5	30 VA 5P20	30 VA CL0.5 + 30 VA 5P20
8,000			
10,000			



IFH-12

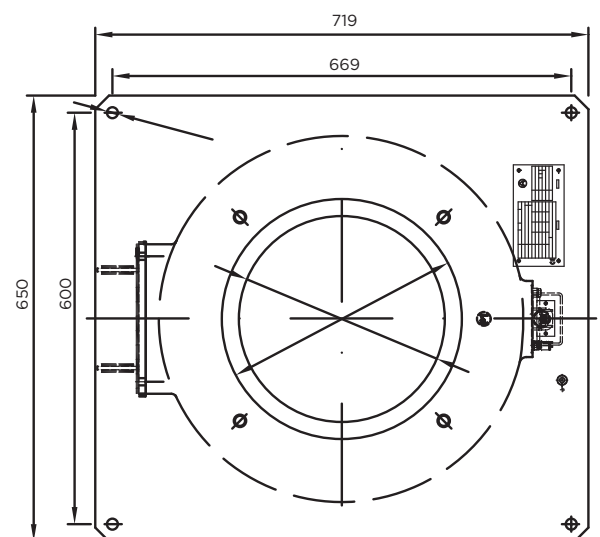
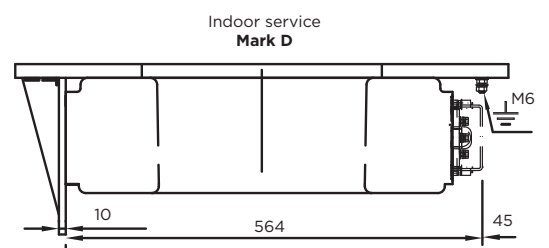
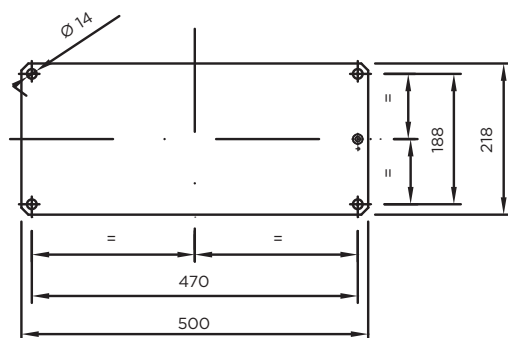
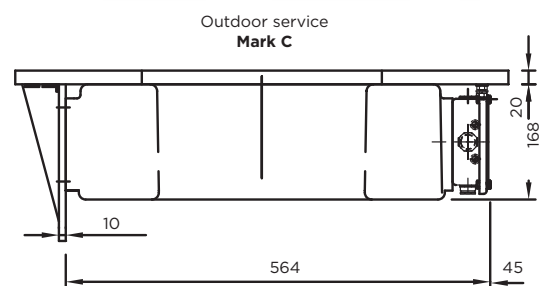
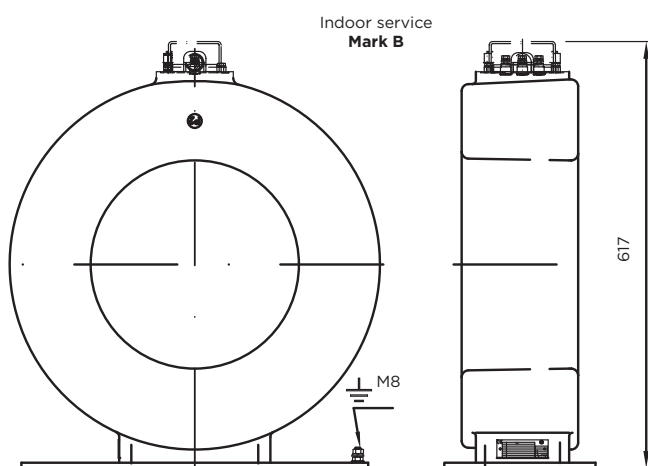
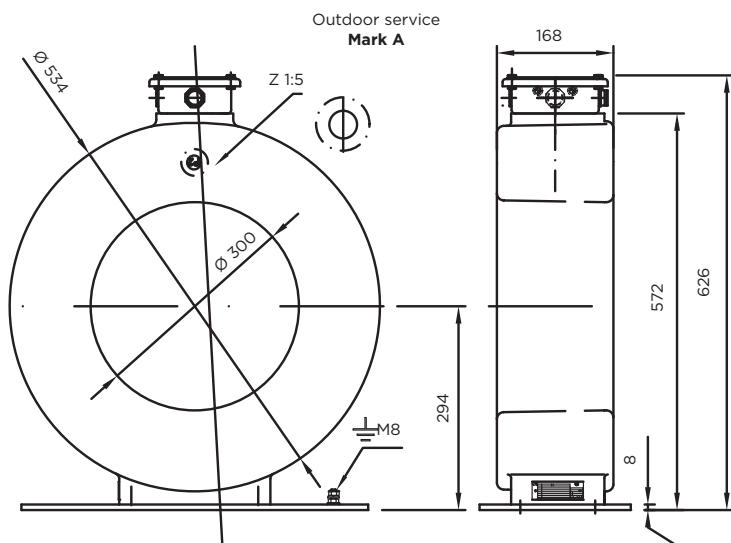

CHARACTERISTICS

Primary current A	ONE SECONDARY		TWO SECONDARIES
	METERING	PROTECTION	METERING + PROTECTION
4,000			
5,000			
6,000	50 VA CL0.5	50 VA 5P20	50 VA CL0.5 + 50 VA 5P20
8000			
10,000			

BAT

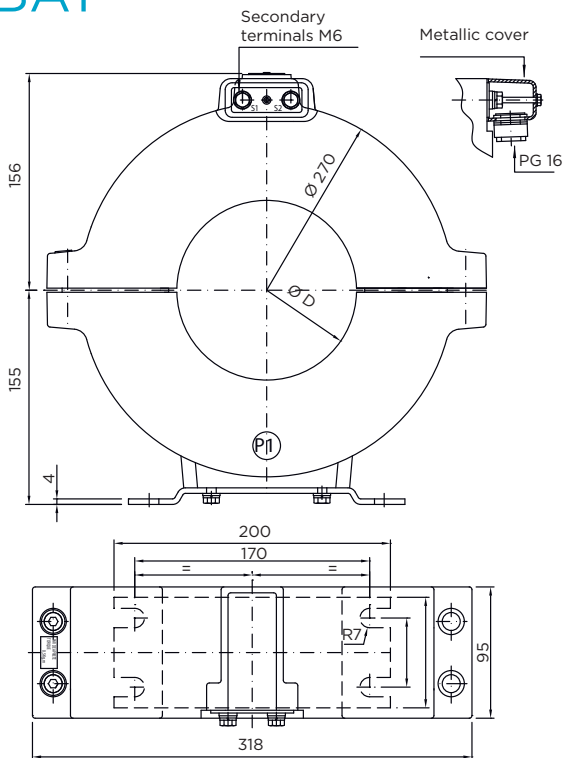

DIMENSIONS

Mark	D
A	130
B	180



CHARACTERISTICS

Primary current A	Mark A		Mark B	
	METERING	PROTECTION	METERING	PROTECTION
200		5 VA 10P10		2.5 VA 10P10
300	2.5 VA CL1	12,5 VA 10P10		2 VA 10P20
400	5 VA CL1	5 VA 5P20	2 VA CL1	2 VA 5P20
600	5 VA CLO.5	15 VA 5P20	5 VA CL1	5 VA 5P20
800	7,5 VA CLO.5	25 VA 5P20	2,5 VA CLO.5	7 VA 5P20
1,000	15 VA CLO.5	30 VA 5P20	5 VA CLO.5	7,5 VA 5P20
1,200	25 VA CLO.5	35 VA 5P20	7,5 VA CLO.5	10 VA 5P20
1,500	45 VA CLO.5	45 VA 5P20	12,5 VA CLO.5	12,5 VA 5P20
1,800	75 VA CLO.5	55 VA 5P20	25 VA CLO.5	15 VA 5P20
2,000	100 VA CLO.5	65 VA 5P20	50 VA CLO.5	15 VA 5P20

BAR

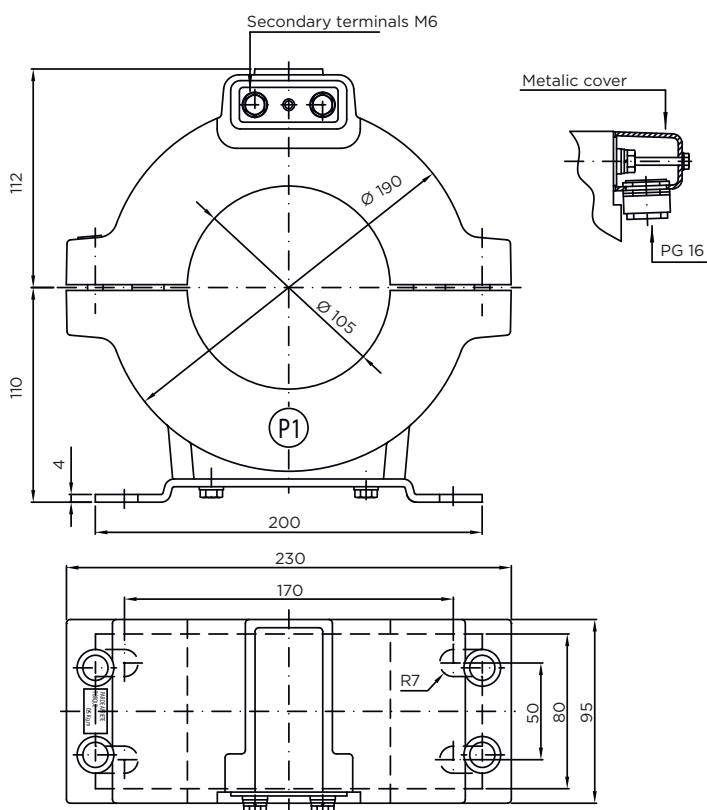

CHARACTERISTICS

Primary current A	METERING	PROTECTION
200		4 VA 10P10
300		2 VA 10P20
400	2 VA CL1	2 VA 5P20
500	5 VA CL1	4 VA 5P20
600	7,5 VA CL1	5 VA 5P20
800	3 VA CLO.5	7 VA 5P20
1,000	7,5 VA CLO.5	7,5 VA 5P20

BAS

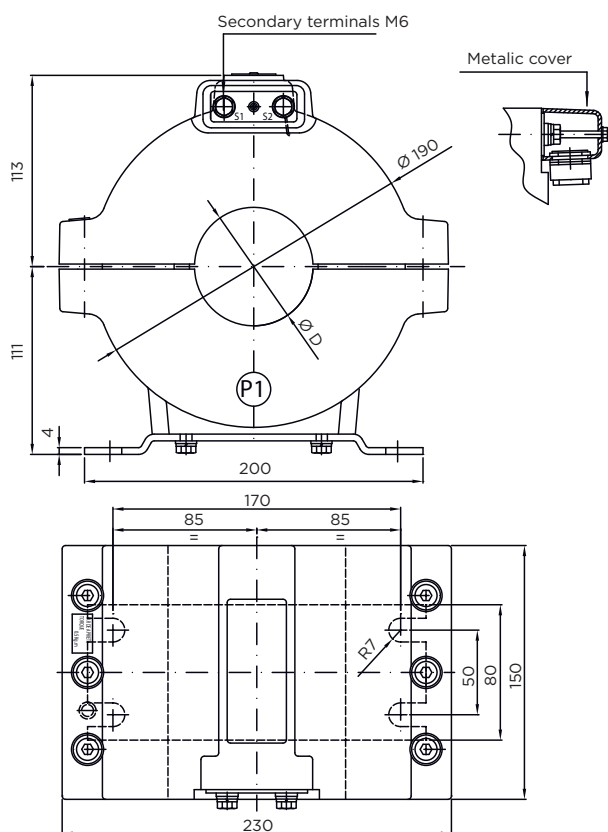

DIMENSIONS

Mark	D
A	70
B	105

CHARACTERISTICS

Primary current A	Mark A		Mark B	
	METERING	PROTECTION	METERING	PROTECTION
150		5 VA 10P10		
200		7.5 VA 10P20		3 VA 10P20
300	10 VA CL1	12.5 VA 10P20		5 VA 10P20
400	5 VA CLO.5	15 VA 5P20	4 VA CL1	7.5 VA 5P20
500	12.5 VA CLO.5	20 VA 5P20	12.5 VA CL1	8 VA 5P20
600	20 VA CLO.5	30 VA 5P20	15 VA CL1	10 VA 5P20
800			7.5 VA CLO.5	12.5 VA 5P20
1,000			25 VA CLO.5	15 VA 5P20



BAR

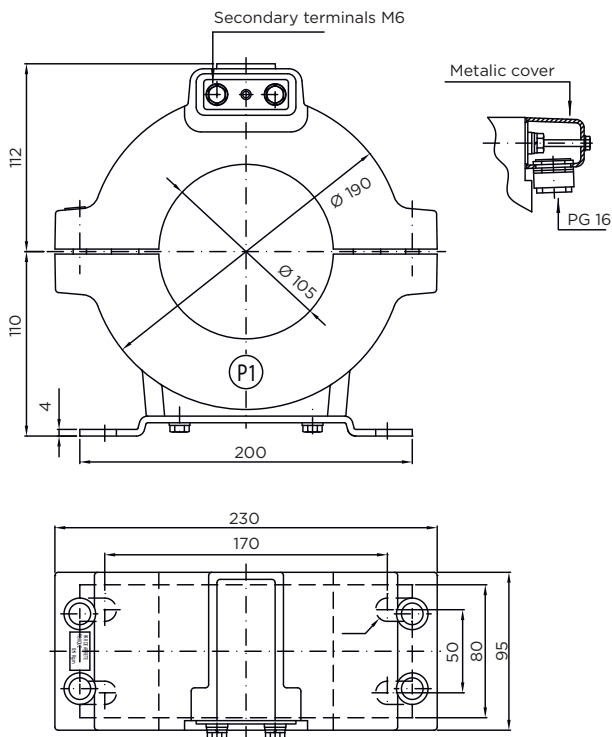

CHARACTERISTICS	
Ratio A	Characteristics
20/1	Burden: 0.1 Oh. Error: at 0.05 In $\pm 15\%$ at In $\pm 10\%$ at 10 In $\pm 15\%$
	Burden: 0.3 Oh. Error: at 0.05 In $\pm 15\%$ at In $\pm 10\%$ at 5 In $\pm 15\%$
	Burden: 0.1 Oh. Error: at 0.05 In $\pm 15\%$ at In $\pm 10\%$ at 10 In $\pm 15\%$
30/1	Burden: 0.3 Oh. Error: at 0.05 In $\pm 15\%$ at In $\pm 10\%$ at 5 In $\pm 15\%$
	Burden: 0.2 Oh. Error: at 0.05 In $\pm 15\%$ at In $\pm 10\%$ at 10 In $\pm 15\%$
50/1	Burden: 1 and 1.5 Oh. Error: at 0.05 In $\pm 15\%$ at In $\pm 10\%$ at 10 In $\pm 15\%$

Customized solutions for any requirement.

1. CURRENT TRANSFORMERS > Homopolar > Indoor / Outdoor

IFH-3

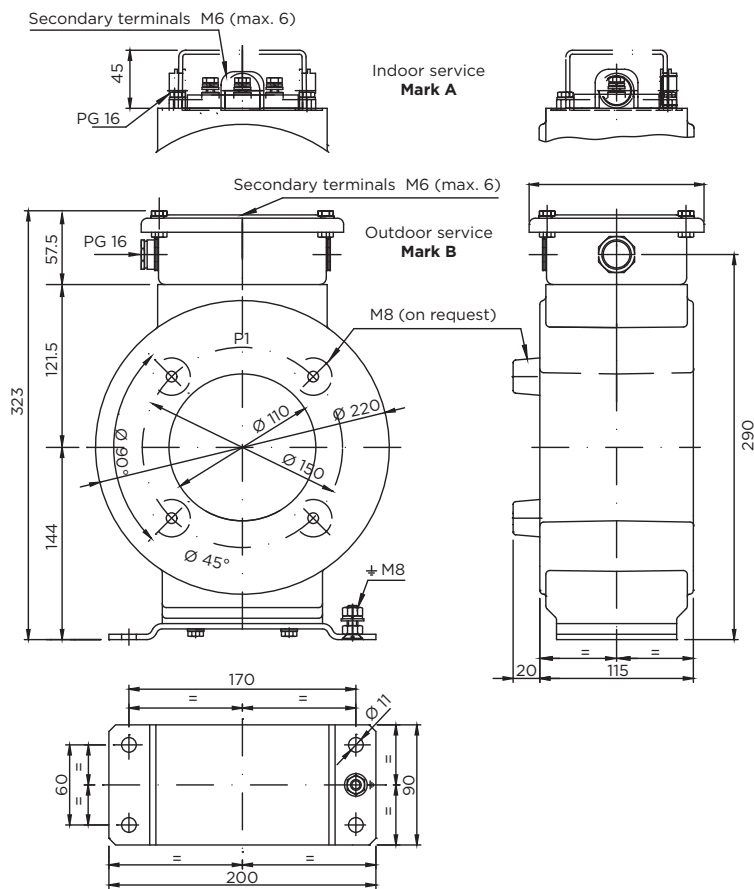

CHARACTERISTICS

Ratio A	Characteristics
10/1	Burden: 0.1 Oh. Error: at 0.05 In ±15% at In ±10% at 10 In ±15%
20/1	Burden: 0.1 and 0.3 Oh. Error: at 0.05 In ±15% at In ±10% at 10 In ±15%
30/1	Burden: 0.1 Oh. Error: at 0.05 In ±15% at In ±10% at 5 In ±15%
50/1	Burden: 1 Oh. Error: at 0.05 In ±15% at In ±10% at 10 In ±15%
60/1	Burden: 1 Oh. Error: at 0.05 In ±15% at In ±10% at 10 In ±15%

ICO-3

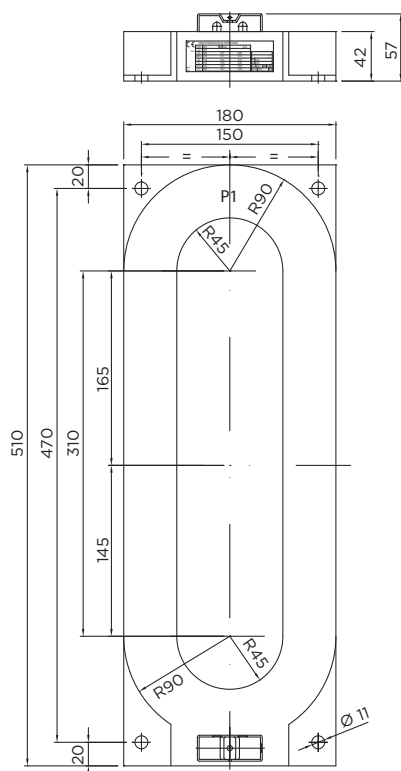

CHARACTERISTICS

Ratio A	Characteristics
20/1	Burden: 0.1 Oh. Error: at 0.01 In ±15% at In ±10% at 10 In ±15%
30/1	Burden: 0.1 Oh. Error: at 0.05 In ±15% at In ±10% at 5 In ±15%
50/1	Burden: 0.1 Oh. Error: at 0.05 In ±15% at In ±10% at 10 In ±15%
60/1	Burden: 0.1 Oh. Error: at 0.05 In ±15% at In ±10% at 10 In ±15%
100/1	Burden: 0.1 Oh. Error: at 0.05 In ±15% at In ±10% at 10 In ±15%



BUSHING CT

Window type current transformers, bushing type, for installation in power transformers, dead tank circuit breakers or Gas Insulated Switchgears (GIS). They are custom made designed based on the each project requirements.



IRM

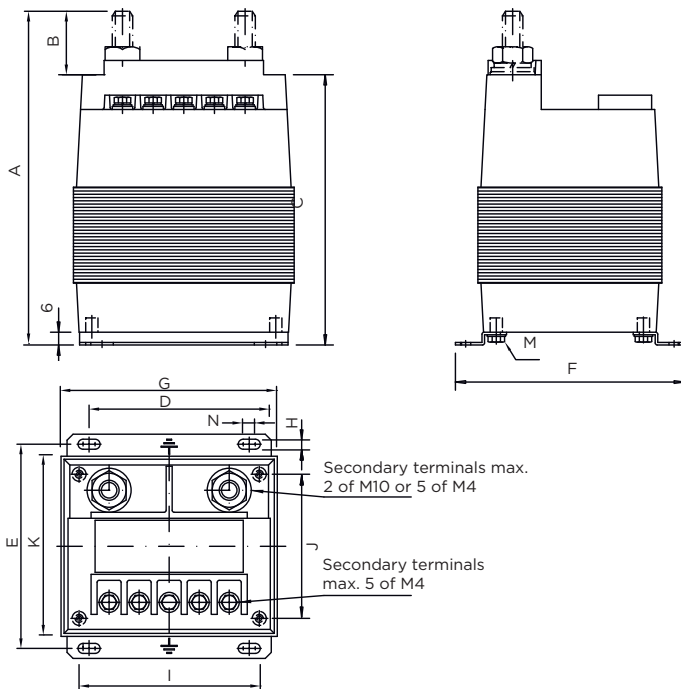

CHARACTERISTICS

Type	Maximum current (A)	METERING	PROTECTION	A	B	C	D	E	F	G	H	I	J	M	N
IRM-2	Up to 15 A	30 VA CL0.5	10 VA 10P20	143	10	135									
	From 15 to 100 A	60 VA CL1	10 VA 5P20	163	30	155	80	102	112	108	5	90	72	90	M4
IRM-3	Up to 15 A	45 VA CL0.5	25 VA 10P20	157	10	150									
	From 15 to 100 A	90 VA CL1	20 VA 5P20	177	30	170	95	119	135	126		105	83	104	
IRM-4	Up to 15 A	75 VA CL0.5	45 VA 10P30	197	10	190									
	From 15 to 100 A	150 VA CL1	45 VA 5P20	217	30	210					7				M6
IRM-5	Up to 15 A	100 VA CL0.5	60 VA 5P20	217	10	210									
	From 15 to 100 A	100 VA CL0.5	60 VA 5P20	237	30	230	120	136	152	150		125	100	125	

VOLTAGE TRANSFORMERS

Resin-cast low voltage transformers for measuring and protection.

ADVANTAGES

- › Transformer can be assembled in any position.
- › Auxiliary services can be supplied.

RANGE

- › Insulation level 0.72 kV.
- › Frequencies: 50 Hz, 60 Hz.

APPLICATIONS

- › Low voltage panel.

1. VOLTAGE TRANSFORMERS > Metering and protection > Indoor

URC

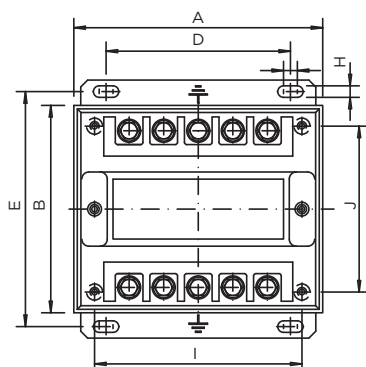
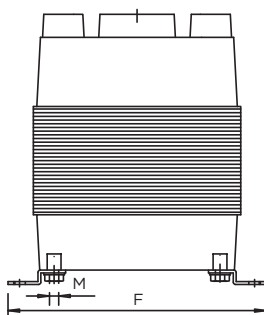
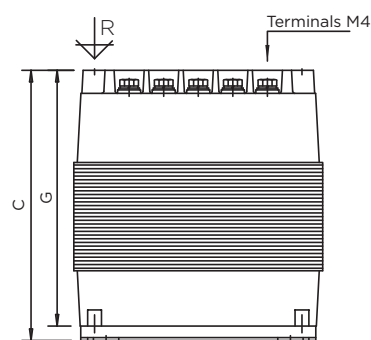

Primary current A	Burden VA			Weight (kg)	A	B	C	D	E	F	G	H	I	J	M
	Class 0.5	Class 1	Thermal												
URC-52	15	45	200	6.2	108	90	111	80	102	112	117	5	90	72	M4
URC-71	25	60	300		126	104	113	95	119	135	120	127	105	83	
URC-72	30	70	450	13.5	150	125	120	120	136	152	168	7	125	100	M6
URC-80	10	20	600												
URC-91	75	150	900	13.5	150	125	120	136	152	168	188	7	125	100	M6
URC-92	150	300	1,300												
URC-93	200	400	1,300	13.5	150	125	120	136	152	168	188	7	125	100	M6
URC-100	30	70	600												

2. INSULATORS & WALL BUSHINGS

Support insulators

Signal insulators

Signalling box

Wall bushings

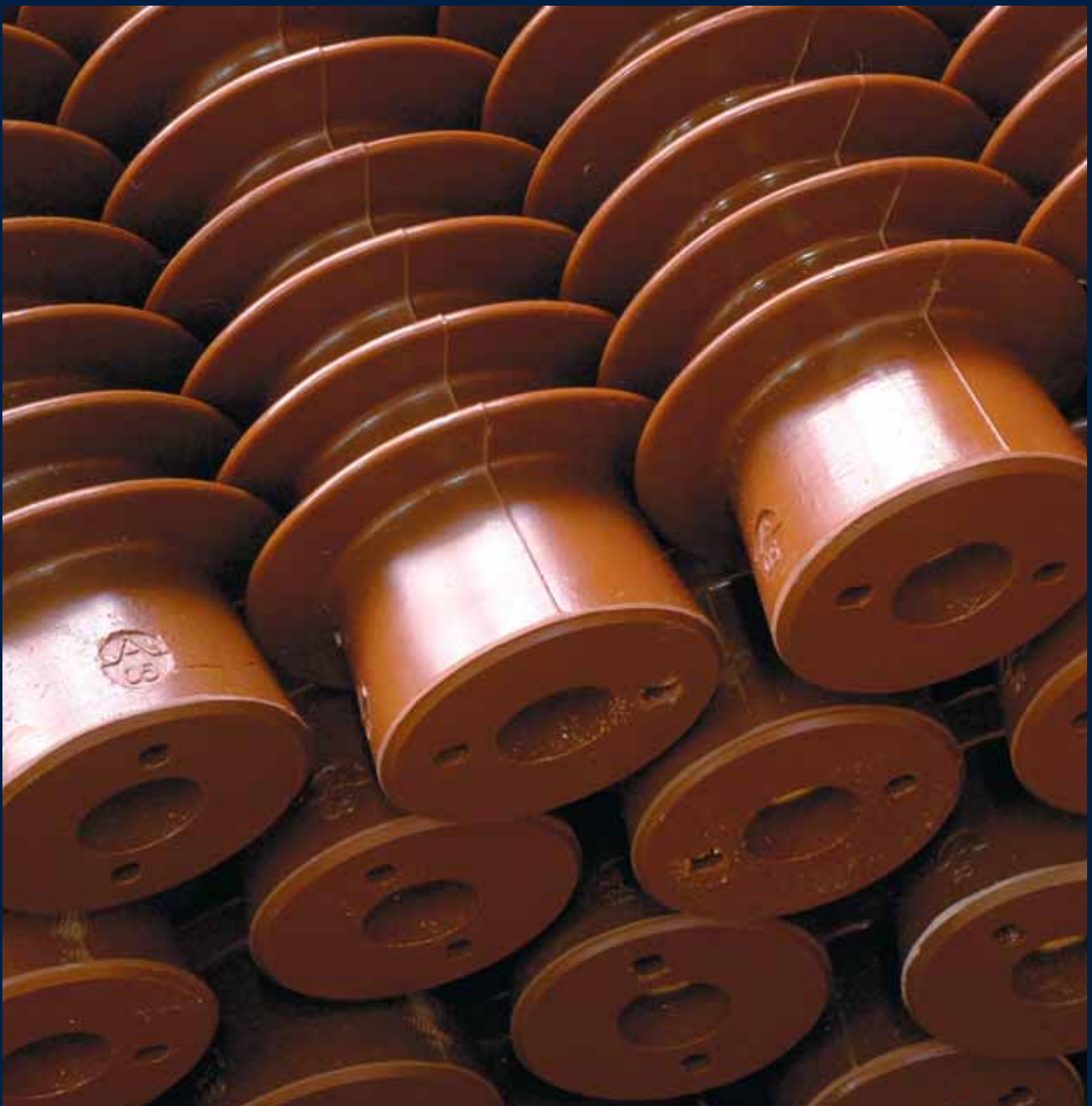

2. INSULATORS AND WALL BUSHINGS > Support insulators > Indoor

AR

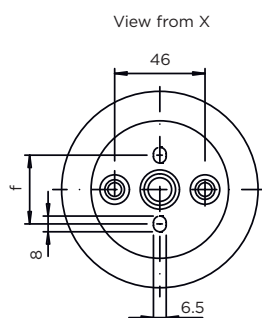
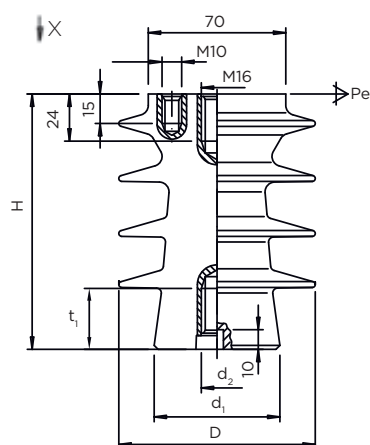

CHARACTERISTICS AND DIMENSIONS

Type	Highest system voltage kV	Rated insulation level		Minimum breaking stress P (kg)	No sheds	Weight (kg)	Creepage distance	H (±0.5)	Ø Máx. D	d ₁	d ₂	t ₁	f		
		Lightning Impulse (BIL) kV	Power frequency kV												
AR-8-60	7.2	60	80	800	3	0.7	200	95	100	56	M16	26	35		
AR-8-75	12	75	38		4	0.98	272	130		64	M16				
AR-8-95	17.5	95	50		6	1.37	340	175		69	M20			35	45
AR-8-125	24	125	70		7	1.65	397	210		74	M20			45	60
AR-8-170	36	170			11	2.57	555	300		84	M24			51	



ARC

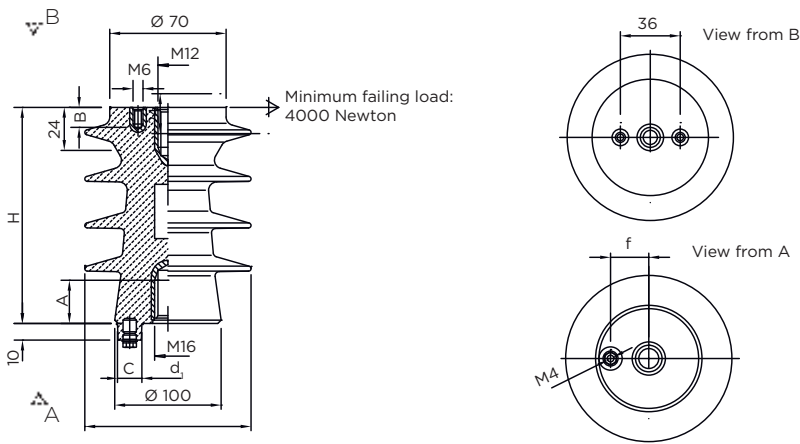

CHARACTERISTICS AND DIMENSIONS

Type	Highest system voltage kV	Lightning impulse (BIL) kV	Power frequency kV	kV min.	kV max.	Height (kg)	Creepage distance	H (±0.5)	d ₁	f	A	B	Ø C
ARC-8-40	3.6	40	10	1.2	3.6								
ARC-8-60	7.2	60	20	2.4	7.2	0.98	272	130	64	23	26	12	
ARC-8-75	12	75	28	4	12								
ARC-8-95	17.5	95	38	5.8	17.5								16
ARC-8-125	24	125	50	8	24	1.65	397	210	74	28	28	10	
ARC-8-170	36	170	70	12	36	2.60	555	300	84				

LAF-1

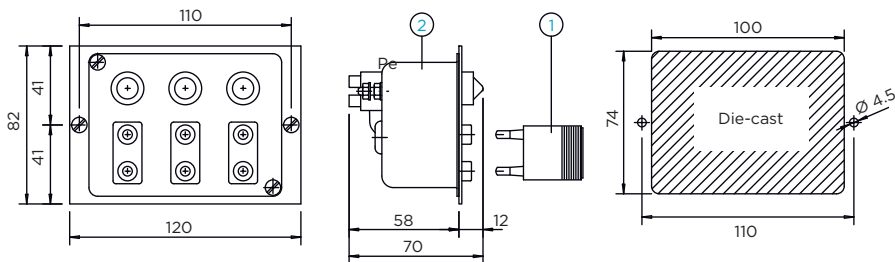

LAF-1 Application

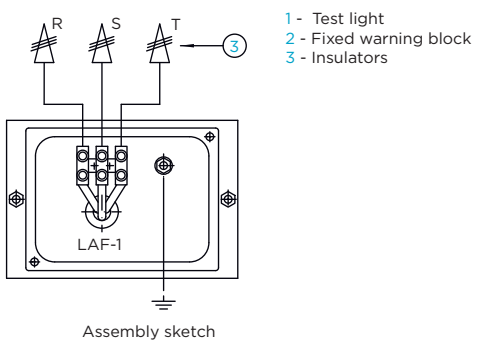



ARTECHE transformers
are installed in over 150
countries.

PRU - PRP



> PRU



> PRP

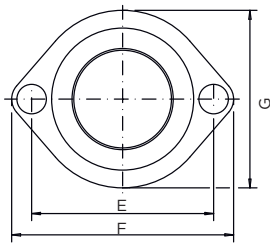
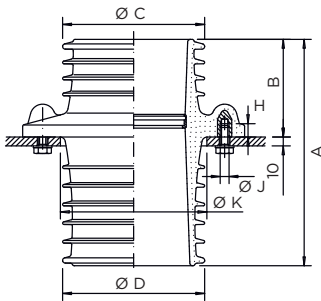

Detail (striped)
Useful zone to place conductor elements

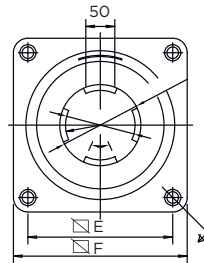
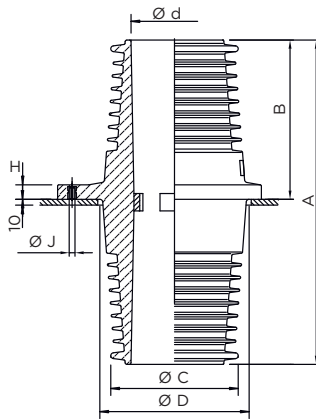
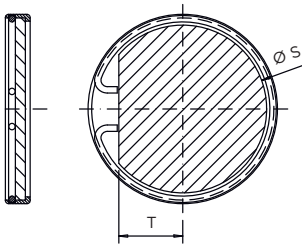

Detail (striped)
Useful zone to place conductor elements

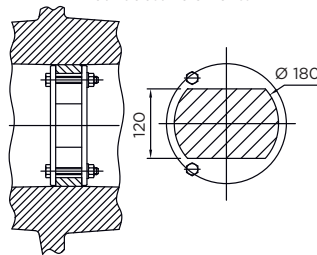

CHARACTERISTICS AND DIMENSIONS

Type	Highest system voltage kV	Lightning Impulse (BIL) kV	Bars max.	Current max.	Weight (kg)	A	B	C	D	d	E	F	G	H	J	K	S	T
PRU-12/75	12	75	60	1,000	2.3	255	110	115	115	68	160	200	160	15	M10	120	65	20
PRU-12/115			100		3.5				160	160	110	205	250	200			165	105
PRU-24/115	24	125	100	2,500	9	425	200	185	185	110	230	280	210	24	M12	190	105	40
PRP-36	36	170	120		32.5	560	275	220	220	120	250	300	300	25	20	257		

2. INSULATORS AND WALL BUSHINGS > Bushings > Indoor

PBD

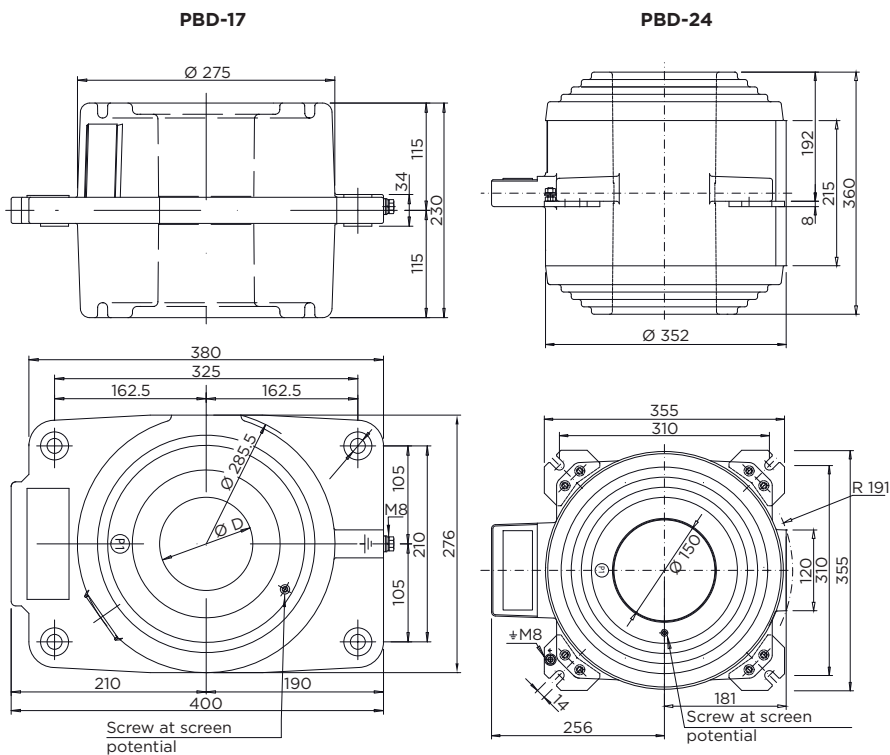

DIMENSIONS

Type	Mark	Ø D	Weight (kg)
PBD-17	A	100	25
	B	130	
PBD-24			45

PBE

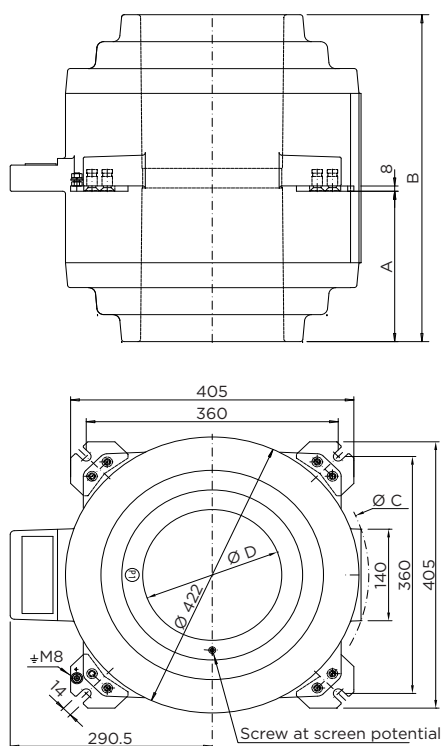

DIMENSIONS

Type	A	B	C	D
PBE-12	255	550	227	275
PBE-24	230	500	225	200

PPL

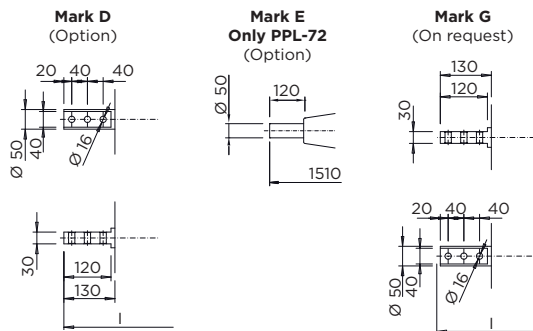
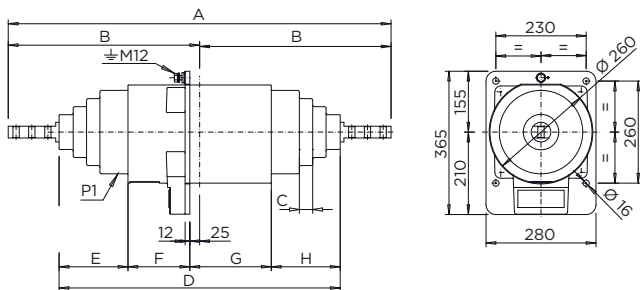

DIMENSIONS									
Type	A	B	C	D	E	F	G	H	I
PPL-12	706	353		442	38.5	157.5	207.5	38.5	706
PPL-36			34	716	175.5			175.5	975
PPL-72				1,270	451	159	209	451	1,530

The innovation undertaken by ARTECHE in instrument transformers during the late years have made them more efficient, with compact designs for an easier transport, store, and installation and to minimize their visual impact.

PPE-36

DIMENSIONS				
Type	Mark	Ø D	E max	L
With primary terminal	A		320	1,412
	B		400	1,492
Without primary terminal	A	125	320	1,125
	B		400	1,205
	C	210	320	1,125
	D		400	1,205



With primary terminal

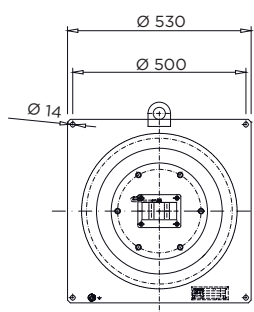
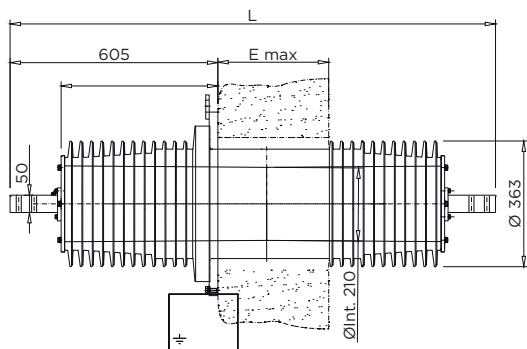

Without primary terminal

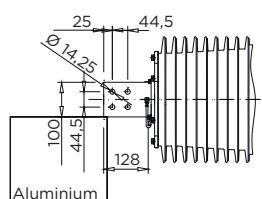
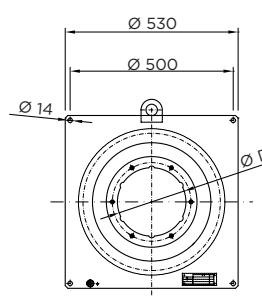
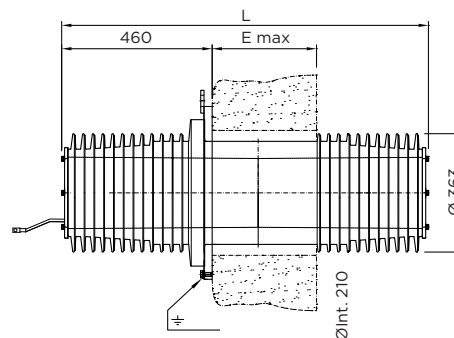

3. MANUFACTURING AND TECHNOLOGY

With *65 years of experience*, ARTECHE guarantees the performance of its transformers regardless of altitude, weather, seismic or environmental conditions.



MANUFACTURING AND TECHNOLOGY

- › Equipment undergoing a continuous innovation process including: computerized systems for transformer calculation, analysis of the distribution of the electric field by FEM, automatic winding machines, casting in epoxy resin or polyurethane by gravity in vacuum tanks or pressurized gelification, controlled polymerization in large ovens.
- › Own laboratories with modern equipment, approved for any routine or type test, either for new developments or for specific requirements from our customers in power generation, transmission, distribution or industry.
- › Approved in laboratories belonging to the International Metrology Committee: PTB (Germany), L.C.O.E (Spain), GOST (Russia), BEV (Austria), GUM (Poland) etc.
- › Large production capacity of more than 50,000 units per year in medium voltage and an almost unlimited number of devices in low voltage, insulators and wall bushings. This capacity allows us to give a quick answer to any requirement.
- › Flexible designs, adapted to any specification, as a result of our strong engineering team located in all our production facilities.
- › Maximum safety with resin-cast transformers in which the core and the winding form a compact block. The resin acts as a dielectric support, protective casing and thermal conductor for the transformer.
- › Equipment compliant to any international or domestic standard: IEC, IEEE, UNE, BS, VDE, SS, CAN, AS, UL, NBR, JIS, GOST, NF, etc.

ARTECHE Group makes a strong commitment to innovation (R+D+i) with an investment of 3,3% from 2013 turnover.



- › Physical and chemical laboratories conduct over 130 tests to certify the quality of raw materials.

4. QUALITY & ENVIRONMENT

Exceeding **environmental regulations**, ARTECHE has been able to minimize the use of hazardous materials, energy consumption and waste generation.



QUALITY & ENVIRONMENT

Everyone in the ARTECHE Group works under the criteria set out in our environmental and quality policy.

A sum of regulated procedures based on communication, teamwork, prevention analysis and continuous improvement, common to the whole organization.

- › Advanced sustainability criteria in production and in the creation and development of new products.
- › Compact designs, manufactured with minimal energy consumption and environmental-friendly materials.
- › Internal and external skill motivation programs.
- › Advanced development of knowledge management.
- › Quality agreements with utilities.
- › Physico-chemical and electrical laboratories for testing under any International Standard.
- › Type test reports issued by KEMA, CESI, LAPEM, RENARDIÈRES, etc.
- › Final testing according to specific customer requirements.
- › Approvals in more than 100 electricity companies.
- › ISO 14001:2004.
- › ISO 9001:2008.
- › OHSAS 18001:2007.

ARTECHE's financial and technological independence gives a privileged position ahead of the challenges in the sector.

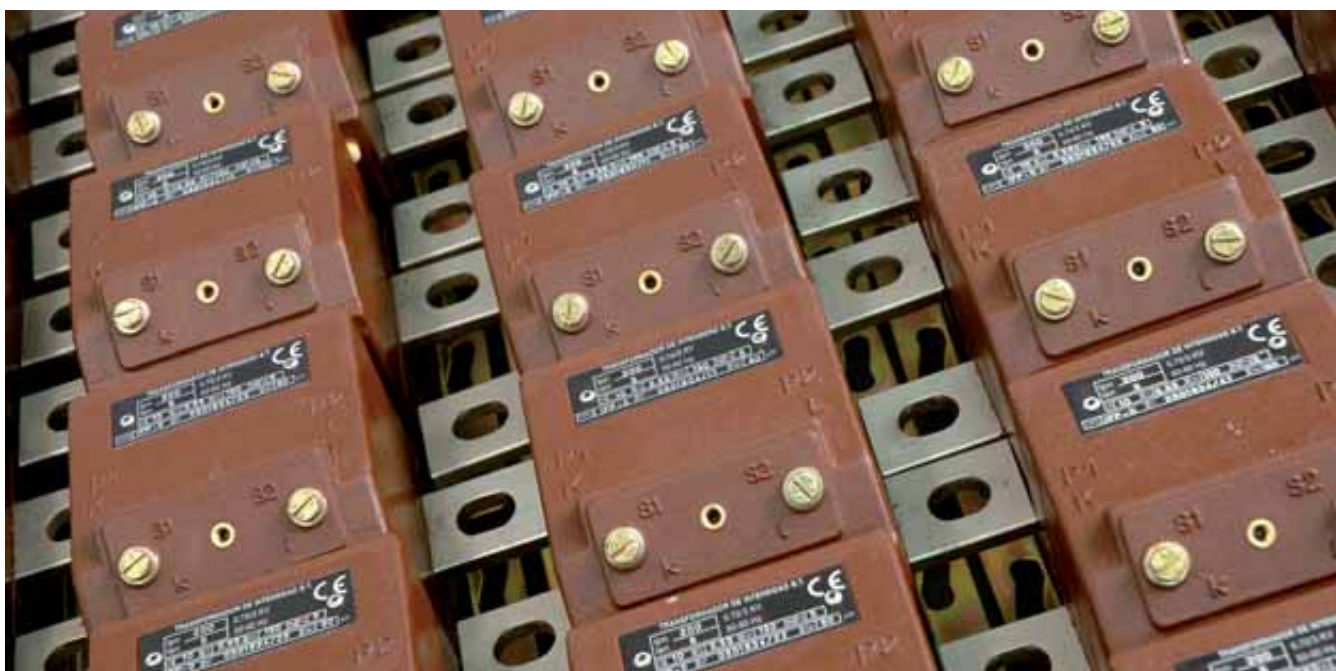

5. SERVICE

Over 70 technical/sales service centers with real knowledge about each customer provide fast and close service.



SERVICE

- › ARTECHE's service is based on a close relationship with the customers, reflected in the integrated post-sale assistance plan and structured client opinion system.
- › In addition to ensuring rapid response, ARTECHE developed a continuous service improvement plan, which sustains an extensive training program with courses, publications, conferences, etc.
- › ARTECHE's focus on service, with a broad experience leading us to be an active participant in the electrical organizations such as: IEC, IEEE, CIGRE, CIRED, ASINEL, etc.
- › ARTECHE has production facilities on four continents (North America, South America, Europe, Asia and Australia) and more than 70 technical/commercial offices. Thus ARTECHE provides effective responses to the requirements of any customer and situation, based on the global knowledge acquired.

ARTECHE has the technology and capabilities of instrument transformers. Thus we provide the best solution available in the market.



- › The solutions ARTECHE has developed and expanded upon have made it a major player participating in the most significant events and workgroups in the electricity sector.

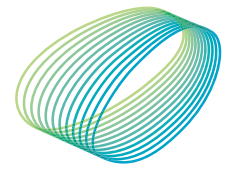

arteche
Moving together

