

saTECH TSB-18

ARTECHE's saTECH 18 test block allows the testing of secondary equipment in a safe and easy way, isolating it completely from the field elements and minimizing any risk for the user.



MAIN FEATURES

- > 18 circuits, with different possible application (trips, currents, voltages).
- > Safe for the user, who will never have access to live parts during insertion or removal operations.
- > Safe operation sequence during plug insertion. First the trip circuits are opened, preventing undesired operations. Then, the voltages and currents are opened, ensuring that the field circuits have been short-circuited before the current circuits are opened (make-before-break sequence).
- > Safe extraction sequence. First, the voltage and current circuits are connected and the user is forced to operate the block before being able to extract the plug completely; so that enough time is guaranteed for the system to stabilize before the tripping circuits are connected.
- > Single test plug for the different test block variants.

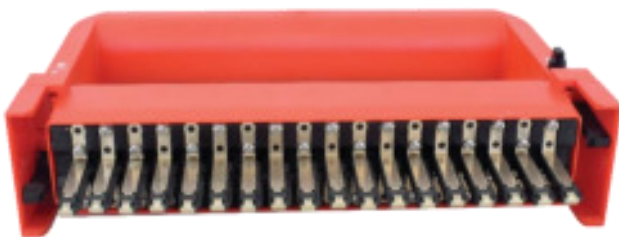

Test plug

APPLICATION

The saTECH test block incorporates 18 circuits, which can be accessed by removing the front cover.



Each of these circuits includes a contact that is normally closed when the secondary equipment is connected to the primary equipment. This connection is made by a pair of terminals on the rear of the test block. Each of the circuits can be of one of the following types: trip, voltage or current.

Current circuits include a mechanism to ensure that the current transformers are short-circuited before they are opened. Two types of short-circuit can be selected, either two-circuit or four-circuit, depending on the application. When ordering the saTECH TSB-18 test block, the user will need to specify which type of circuit (trip, voltage or current) they need, and in the case of current circuits they must also specify the type of short circuit required (2 or 4 circuits).

The current circuits are marked with a different color that allows them to be easily identified, even when the plug is inserted.

During plug insertion, the circuits are prepared to be able to carry out the tests of the secondary equipment, following the following sequence:

1. Opening of the tripping and signaling circuits.
2. Short-circuiting of the current transformer circuits on the field side.
3. Opening of the voltage and current circuits.

Once the plug is inserted, the protection relay is ready for testing, and this will not affect the rest of the system, from which it has been separated.

The field elements are automatically isolated by shorting the current circuits and opening the voltage and tripping circuits.

The robust TSB-18-P plug includes a guide that facilitates insertion in the correct position and ensures that all contacts of the same type are opened simultaneously. Once the plug is inserted, it can be locked to prevent unintentional extractions.

There are 36 connectors in the test plug that allow the use of safety banana plugs. 18 banana plugs are used in the injection test on the secondary equipment, and the other 18 give access to the field elements. Both parts (the secondary equipment side and the field side) are identified clearly on the plug.

Each banana plug on the test plug is identified by a number corresponding to the same number on the test block.

During plug extraction, a retention system requires the extraction to be made in two movements, with the following sequence:

Phase one:

1. Connection of voltage and current circuits (still short circuited).
2. Opening of the short-circuit on current transformer circuits.

Phase two:

3. Connection of the trip circuits.

Before moving on to the second phase, it is necessary to act on the plug's retention system. This operation will allow the voltage and current values to stabilize after transients during connection, and will avoid unwanted trips when connecting the trip circuits.

During plug insertion and extraction there are no bounces that could damage the current transformers.

REAR CONNECTIONS

Maximum number of ring terminals that can be connected: 2.

Cable up to 4 mm² or 12 AWG.

Maximum outer diameter of the ring connector 9 mm.

M4 Phillips head screws are supplied with the test block.

TECHNICAL SPECIFICATIONS

Technical Data		
Dielectric strength IEC 60255-5	TSB-18 & TSB-18-P	2kV between input and output contacts
		2kV open contacts, plug inserted
		5kV rms for 1 minute between all terminals connected together and the ground terminal
		2kV rms for 1 minute between any pair of contacts, including adjacent contacts
		5kV rms for 1 minute between any alternating contact pair, provided the intermediate contact pair is not used
Current flow	TSB-18	All circuits allow 20A continuously or 400A for 1s
	TSB-18-P	All circuits allow 10A continuously or 200A for 1s
Maximum operating voltage	TSB-18 & TSB-18-P	300 volts AC or DC continuously
Environmental conditions	Temperature	In storage -25°C to +70°C In operation -25°C to +55°C
		IEC 60068-2-1 Cold
	Moisture	IEC 60068-2-2 Dry Heat
		IEC 60068-2-78 56 days at 93% relative humidity and +40°C
Enclosure protection	IEC 60529 TSB with IP50 front cover TSB (without front cover) and TSB-P IP20	
Mechanical characteristics	Vibration	IEC 60068-2-6 IEC 60068-2-27
ECM compliance	89/336/EEC	This product has been classified as electromagnetically safe, and therefore is excluded from the European EMC Directive

MODEL SELECTION

The configuration of the 18-circuit equipment must be done via the platform:

<https://www.arteche.com/es/configurador-de-producto/configurador-bloques-de-pruebas-18-contactos>

For further details, please refer to the user manual, MU_saTECH -TSB-14/18

DIMENSIONS, ASSEMBLY AND CONNECTIONS

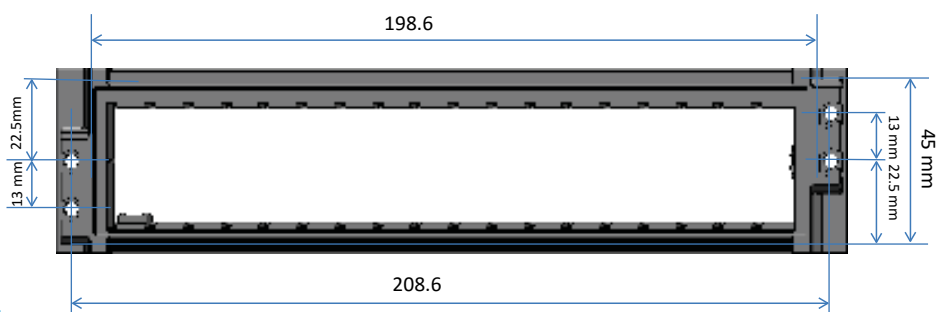
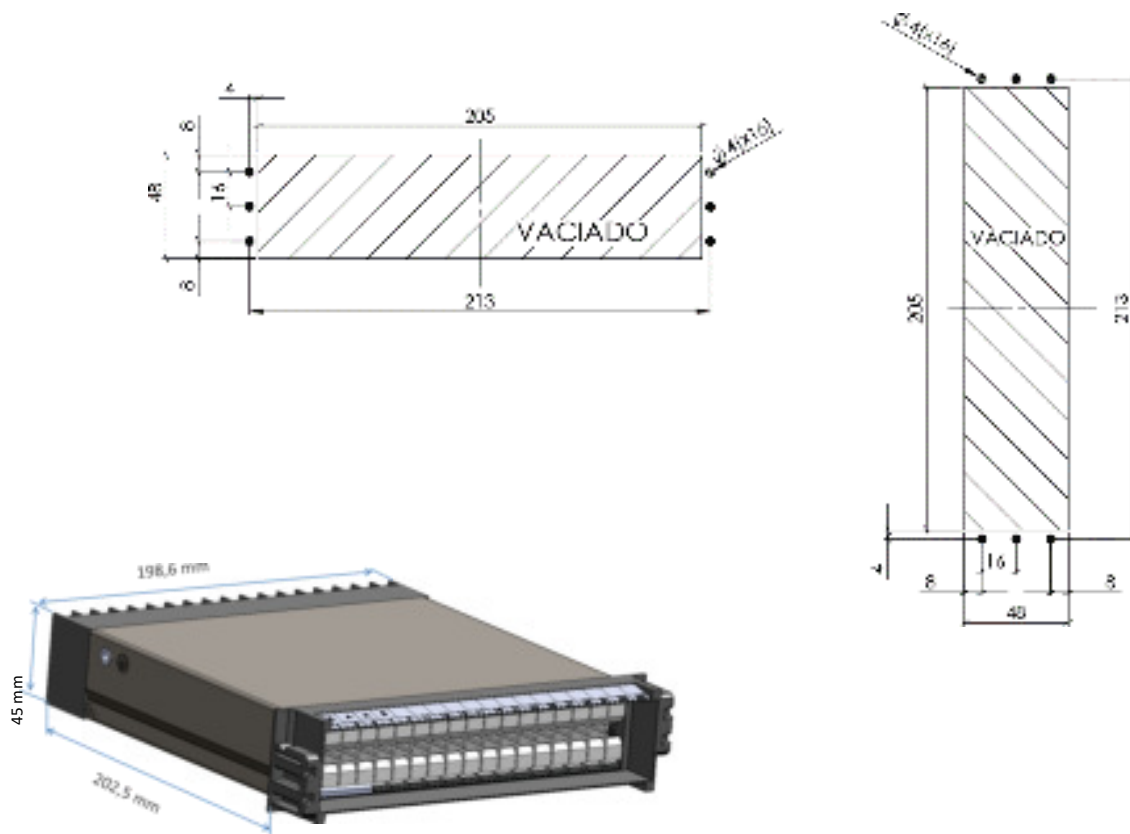

APPLICATION EXAMPLE

